

# F-360

*Plain-paper Digital Fax*

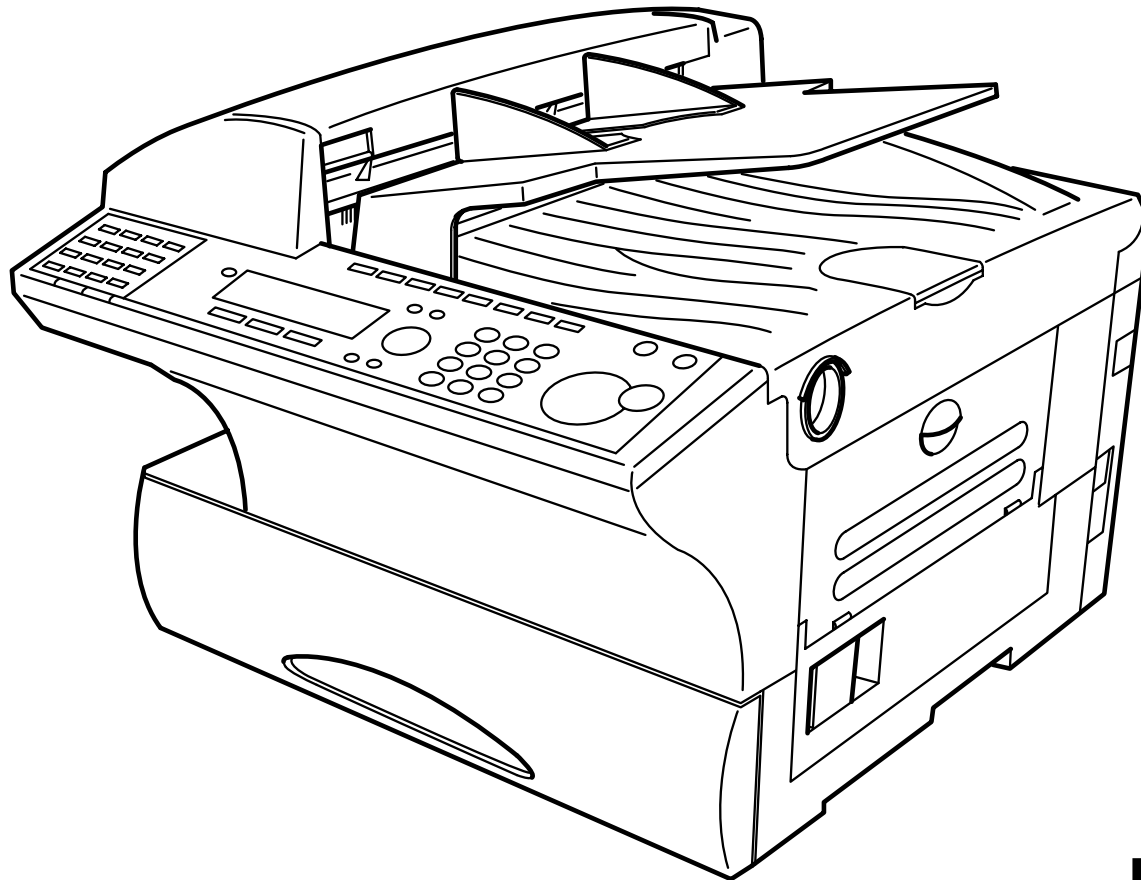
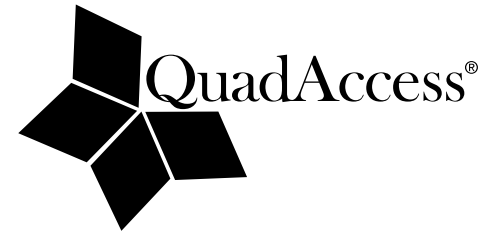

*Operating Instructions*

**Muratec**<sup>™</sup>  
The Fax Specialists.

# Welcome ...

## **Thank you!**

Thanks for selecting a Muratec fax machine for your business.

***Before you begin***, please note that before your fax can be used and before you can turn on power to the unit for the first time, there are important precautions to take. Please see page 1.5 for more information.

**muratec™**

## Trademarks

*Muratec*, the Muratec logo and all Muratec fax product names contained herein are trademarks of Muratec America, Inc. QuardAccess is registered trademark of Muratec America, Inc.

*ENERGY STAR* is a registered mark of the United States Environmental Protection Agency.

## Copyright

Copyright © 2001 by Muratec America, Inc. All rights reserved.



As an *ENERGY STAR*® partner, Muratec America, Inc., has determined that this product meets the *ENERGY STAR*® guidelines for energy efficiency.

## Energy saving

Your machine can save the energy with its Energy Saving Mode.

In the Energy Saving Mode the printer will not use its fusing lamp. If your machine receives a fax message or if any key is pressed your machine will automatically wake up. The time for the machine to enter the Energy saving mode can be selected from 1 to 240 minutes. For details, see “EasyStart,” page 1.20.



Super G3 is an extension of Group 3 fax technology standards, allowing the use of high-speed ITU-T v.34 modems for 33.6 Kbps transmission and high-speed protocols for rapid handshaking.

**JBIG** — Joint Bi-level Image experts Group, the new ITU-T standard image data compression method. As JBIG compresses the data more efficiently than MMR, it is especially effective when transmitting halftone (grayscale) image document.

This manual and any updates to it can be found online at [www.muratec.com](http://www.muratec.com)

Go to the “Products” section of this site, then click on “F-360”

# Before using your Muratec fax machine

## Where to set up your fax machine

Follow these guidelines when setting up your fax machine:

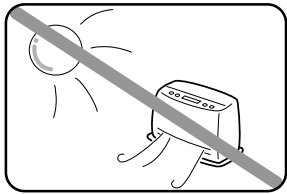

### Away from direct sunlight

To avoid overheating, set up your fax machine away from direct sunlight or a heater.

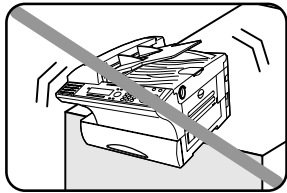

### Level, and vibration-free

To avoid damage to the machine or injuries, set the fax machine up in a level, vibration-free location.

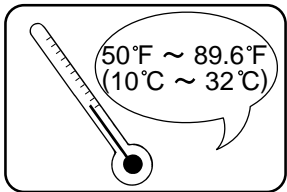

### Avoid extreme high / low temperature

Use your fax machine within the temperature range of 50° F to 89.6° F (10° C to 32° C).

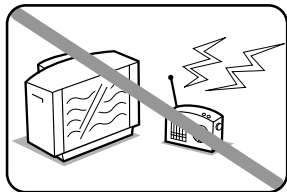

### Away from a television or radio

Many appliances and office equipment, including televisions, radios, copy machines, air conditioners and computers, can generate electronic noise that can interfere with the operation of your fax machine.

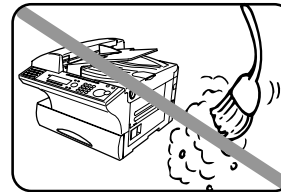

### Clean

Dust buildup can damage your fax. Periodically clean your fax machine as described in the operating instructions. **Do not use a dust cover**, which can cause damaging overheating.

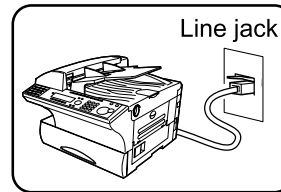

### Near a phone jack

Your fax machine uses a standard (modular) telephone jack, also known as an RJ-11.

### Space around the fax machine

To ensure proper ventilation and easy operation, set up the machine in an area that meets the minimum requirements for clearance as illustrated below.

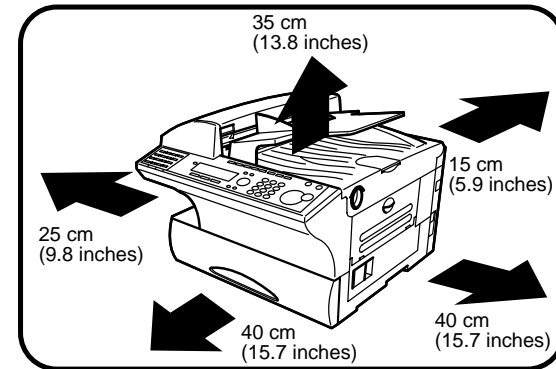

## Power requirements

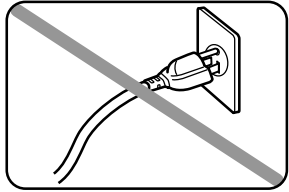

### Plug in the power cord

Plug the power cord carefully and completely into a wall outlet. Do not leave any portion of the electrical cord's metal prongs exposed. Doing so could cause a fire and poses a risk of electrical shock.

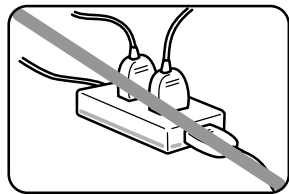

### Do not share an extension cord connector with other plugs

It can cause electrical shock.

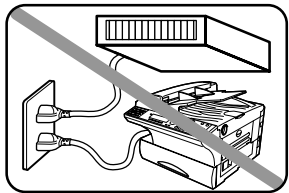

### Do not share an outlet with a large appliance

High-consumption appliances such as a refrigerator or air conditioner can cause "draw-downs" which could damage your fax machine.

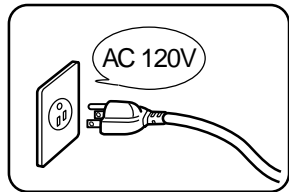

### 120 VAC outlet

Use a standard three-pronged 120 V electrical outlet to power your fax machine. Using any other electrical outlet will cause damage to your fax.

### For domestic use only

Never use your fax machine outside the country in which you purchased it. Doing so may violate telecommunication and safety regulations of that country, and variations in electrical and telephone standards can cause poor performance and damage to your fax.

## General Precautions

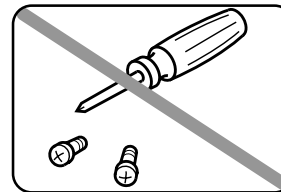

### Never disassemble your fax machine!

Disassembling your fax machine can cause serious injury to you and damage to your fax. If service is required, call your authorized Muratec dealer.

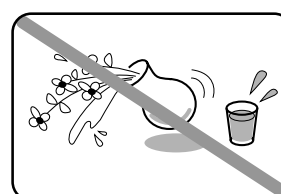

### Keep away from liquids

Keep liquids and metal pins or other objects away from your fax machine. If something falls into the fax machine, remove the plug from the outlet, and call your authorized Muratec dealer.

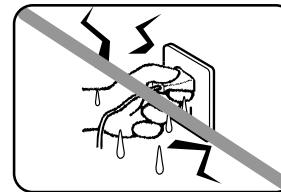

### Never handle your fax machine or power cord with wet hands

Never touch your fax machine or power cord if your hands are wet.

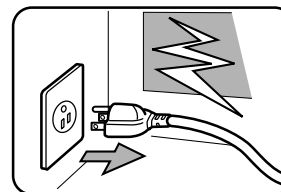

### During electrical storms, disconnect the plug from the outlet

Electrical storms can cause electrical shock or damage to the fax machine.

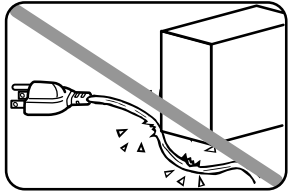

**Do not put furniture or equipment on the power cord**

Do not put anything on or over the electrical power cord, and do not route the power cord under rugs or carpets. Doing so can damage the power cord or fax, and can cause fire or electrical shock.

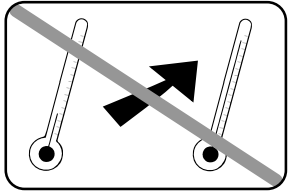

**Avoid temperature fluctuations**

Sudden changes in temperature can cause damaging condensation to form inside your fax machine.

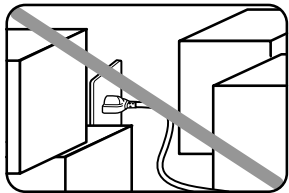

**Allow clearance around the outlet**

Don't stack boxes or furniture around the outlet.

**Use supplies manufactured specifically for Muratec machines**

Using toner cartridges and other supplies that are not manufactured specifically for Muratec machines may affect the operation of your unit.

**Use caution when carrying the machine**

When you lift and carry the machine, the slots as shown in the illustration below should be held. Do not hold the any parts of the machine except the following slots to lift; damage could result.

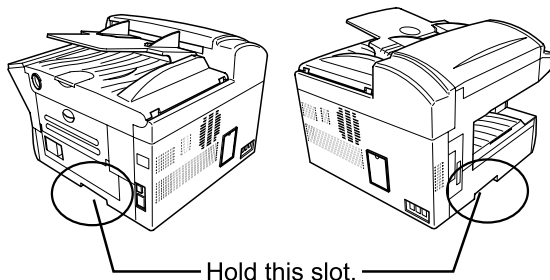

**Storing and handling toner and drum cartridges**

To avoid damage to your fax machine and to assure the best performance possible, follow these guidelines when storing and handling toner and drum cartridges:

**Store the cartridge**

Store the cartridge at a constant temperature within a range of 32° F to 95° F (0° C to 35° C). To avoid dew do not store cartridges in locations subject to extreme fluctuation of temperature and humidity.

**Do not stand the cartridge on its end and do not store it upside down.**

**Do not open the protective bag of the cartridge until you are ready to install the cartridge.**

**Do not store cartridges in areas of:**

- Direct sunlight
- Dusty conditions
- Near floppy disks or other computer media, computer screens, or any other materials sensitive to magnetic fields.

**DO NOT BURN TONER CARTRIDGES!**

The toner powder is extremely flammable. Exposure to flame can cause toner cartridges to burn or explode, causing serious injury.

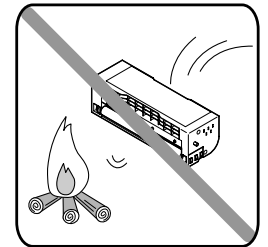

**Be careful not to get the toner powder in your eyes.**

If the toner powder gets in your eyes, wash your eyes well and see a doctor.

**Keep cartridges away from water or oil.**

**Do not expose cartridges to direct sunlight.**

**Do not expose the cartridges to static or other electrical shock.**

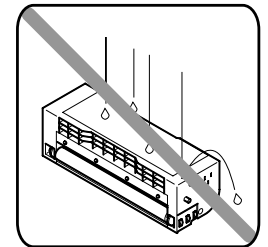

*This page intentionally blank.*

# Welcome to your Muratec fax machine!

These instructions are divided into the following sections.

- **“Getting started”** (page 1.1) describes how to set up your machine, operating tips and some important settings that you should perform before you use your machine.
- **“Basic operations”** (page 2.1) describes the basic operations of the transmission, reception and copying.
- **“Advanced features”** (page 3.1) describes the convenient features of your machine.
- **“Changing the default settings”** (page 4.1) describes how to change the settings of your machine.
- Finally, **“Just in case ...”** (page 5.1) helps you if you ever have a problem with your machine. It also tells you how to give your machine the kind of easy, sensible care that should keep troubles to a minimum.

Thanks for choosing Muratec.

## Find your serial number and write it down

Please note that your machine's *serial number* is located on the *bar code label* as shown on the drawing at right. Use the blank at the bottom of this column to copy this down *before* you set up your machine.

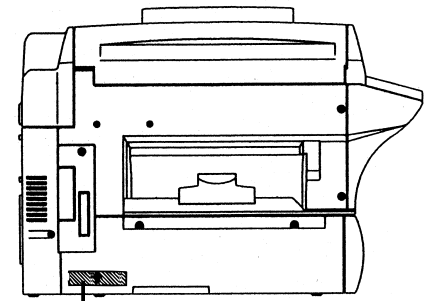

Bar code label

Close up, the bar code label looks something like this, but with a different set of numbers:



Please copy down your machine's serial number below for future reference, and note the machine's model number:

My machine's serial number: \_\_\_\_\_

My machine's model number: Muratec F-360



# Table of Contents

## Getting started

Packaging contents	1.1
Parts of your machine	1.1
Control Panel Overview	1.3
Setting up	1.5
Pick an installation spot	1.5
Power tips	1.5
Installing the printing supplies	1.5
Attach the paper-handling parts	1.6
Plug in and power up	1.7
Adjust the monitor speaker's volume	1.7
Loading paper	1.7
Operating tips	1.10
Symbol and terms	1.10
How to operate the machine	1.10
Searching the functions using the cursor key	1.11
Entering characters	1.12
Function table	1.13
EasyStart (Initial settings)	1.18
Getting started	1.18
Clearing stored settings	1.18
Entering initial settings	1.18

## Basic Operations

Sending faxes	2.1
Guidelines	2.1
Memory transmission	2.2
Quick memory transmission	2.2
Memory overflow message	2.2
Real time transmission (Non-memory transmission)	2.3
Sending a fax	2.3
Sending a fax using monitor/call key or a handset	2.4
Redialing	2.5
Reviewing or canceling commands	2.6
Receiving faxes	2.8
Answering calls manually	2.8
Reception modes	2.8
How to select the fax reception mode	2.9
If the paper runs out while fax reception	2.9

Making copies	2.10
Changing the reduction ratio	2.10
Using the bypass tray	2.10
Memory overflow message	2.11
If the paper runs out while copying	2.11
Using your fax machine as a phone	2.12
Dialing a telephone number	2.12
On-hook dialing	2.12
Redial	2.12
Call request	2.12
Changing the dialing type	2.12
Dialing in the event of a power failure	2.12
Attaching an optional handset	2.13
Attaching a second phone	2.13

## Advanced Features

Autodialer	3.1
Autodialer basics	3.1
Using one-touch keys	3.2
Using speed-dial numbers	3.4
Call group dialing	3.6
EasyDial directory dialing	3.8
Broadcasting	3.9
Reviewing or canceling parts of a broadcast	3.10
Delayed transmission	3.11
Setting up a delayed transmission	3.11
Batch transmission	3.12
Creating or modifying a batch box	3.12
Printing a list of batch boxes	3.13
Storing a document for batch transmission	3.13
Printing a list of stored batch documents	3.13
Printing a document stored in a batch box	3.13
Erasing a document stored in a batch box	3.14
Erasing an empty batch box	3.14
Polling	3.15
Regular polling	3.15
Being polled	3.15
Printing a stored polling document	3.16
Erasing a stored polling document	3.16

Soft keys	3.17
Special features	3.18
Macro keys	3.18
Fax & Copy	3.21
Setting the journal and the report	3.22
Separate each received document (Separator Page)	3.24
Cover page	3.24
OneLine + distinctive ring detection	3.25
Call request	3.26
The power of QuadAccess®	3.27
F-Code Boxes	3.27
Programmable one-touch keys	3.38
Security features	3.46
The passcode	3.46
Security reception	3.46
Masking the pin	3.48
Setting Block Junk Fax	3.50
Using department codes	3.52

### Changing the default settings

Settings for transmission	4.1
Scan settings	4.1
Setting ecm	4.2
Memory transmission	4.2
Quick Memory transmission	4.2
TTI transmission	4.2
Settings for reception	4.3
Print settings	4.3
Setting the number of rings	4.4
Image Rotation	4.4
Settings for dialing	4.5
Changing the dialing pause length	4.5
Changing redial settings	4.5
Settings for copying	4.6
Scan settings	4.6
Copy print settings	4.7
Settings for operation	4.8
Setting the silent mode	4.8
Setting Sleep mode (Energy saving mode)	4.9
Setting paper source	4.9
Adjusting the machine's clock	4.9
Setting 2-bin tray (Option)	4.9
Printing your settings	4.10

### Just in case ...

Clearing paper jams	5.1
If an original document jams	5.1
If a printout jams inside your machine	5.2
Print quality problems	5.3
Troubleshooting	5.5
Errors	5.8
Caring for your fax machine	5.11
Corrective cleaning	5.11
If you have unsatisfactory printout quality	5.12
Common questions	5.13
General questions	5.13
Sending faxes	5.13
We're here to help you!	5.13
Receiving faxes	5.15
Polling	5.15
Glossary	5.16

### Appendix and index

Specifications	AI.1
Regulatory information	AI.3
Limited warranty	AI.4
Index	AI.5

# Getting started

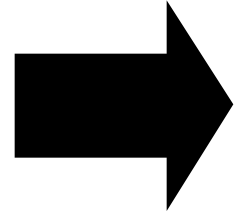

*This chapter describes how to set up your machine, operating tips and some important settings before you use your machine*

Packaging contents .....	1.1
Parts of your machine .....	1.1
Control Panel Overview .....	1.3
Setting up .....	1.5
Operating tips .....	1.10
Function table .....	1.13
EasyStart (Initial settings) .....	1.18

# Packaging contents

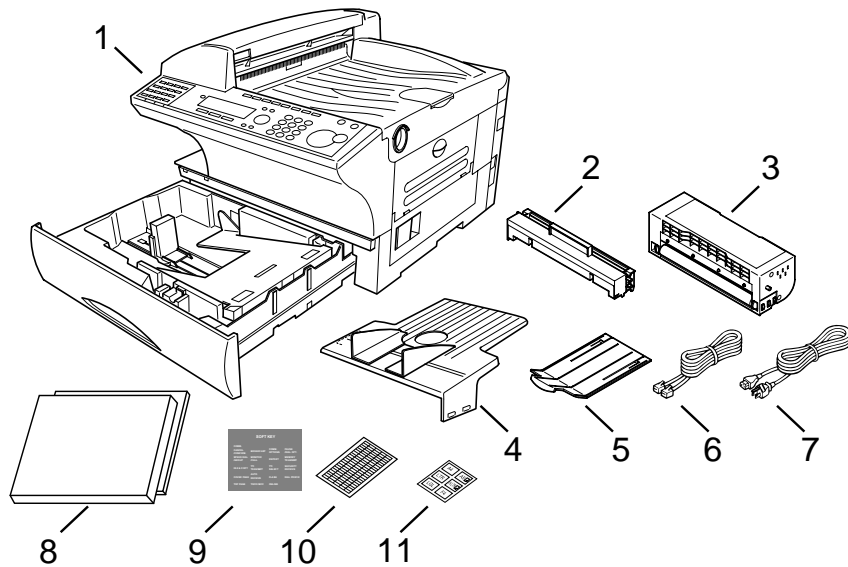

Included in your machine's packaging:

- |   |   |
|---|---|
| 1. Main unit with 500-sheet paper cassette installed (paper not included) | 7. AC power cord                              |
| 2. Drum cartridge   | 8. Operating instructions and Quick reference |
| 3. Toner cartridge  | 9. Soft Key labels                            |
| 4. Document tray  | 10. One-touch labels                          |
| 5. Extension paper tray   | 11. Paper size stickers                       |
| 6. Telephone line cord  |   |

**Note:** Be sure to save the box (or boxes) and packing materials for reshipment.

# Parts of your machine

**Note:** These terms and features of your fax will be explained in the coming pages.

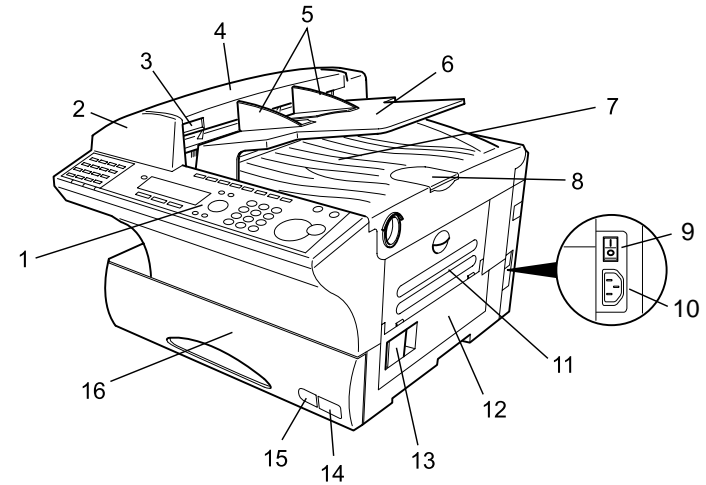

- 1 Control Panel** — The keys you use to operate your machine. (See pages 1.3–1.4 for more details.)
- 2 ADF (Automatic Document Feeder)** — The ADF automatically feeds original document into the machine, one at a time. It can hold up to 80 pages of letter-sized document.
- 3 Scanner cover release** — Pull up on this to open the scanner cover.
- 4 Scanner cover** — Open this cover to remove original document jams.
- 5 Document guides** — Adjust these to fit the width of the original document so it will feed properly into the machine.
- 6 Document tray** — Holds original documents in place for scanning into the machine.
- 7 Top cover** — Open to provide access for changing the toner and drum cartridge (or, occasionally, fixing printout jams).
- 8 Document stopper** — Holds original documents after they've been scanned into the machine for faxing/copying.

- 9 AC power switch** — Turns your fax machine on and off.
- 10 AC power jack** — Where you plug in the AC power cord.
- 11 Bypass tray** — Open the bypass tray to use the paper that is not set in the paper cassette. It can hold up to 50 sheets of paper. For details about paper capacity of the bypass tray, see “Specifications,” page A1.2.
- 12 Side cover** — Open to fix a printout jam.
- 13 Side cover release** — Pull this to open the side cover.
- 14 Recording paper size sticker** — Shows the size of the paper that is set in the paper cassette.
- 15 Recording paper level indicator** — Shows the level of the paper supply without requiring you to open the paper cassette.
- 16 Paper cassette** — Set paper here. It can hold up to 500 sheets. For details about paper capacity of the paper cassette, see “Specifications,” page A1.2.

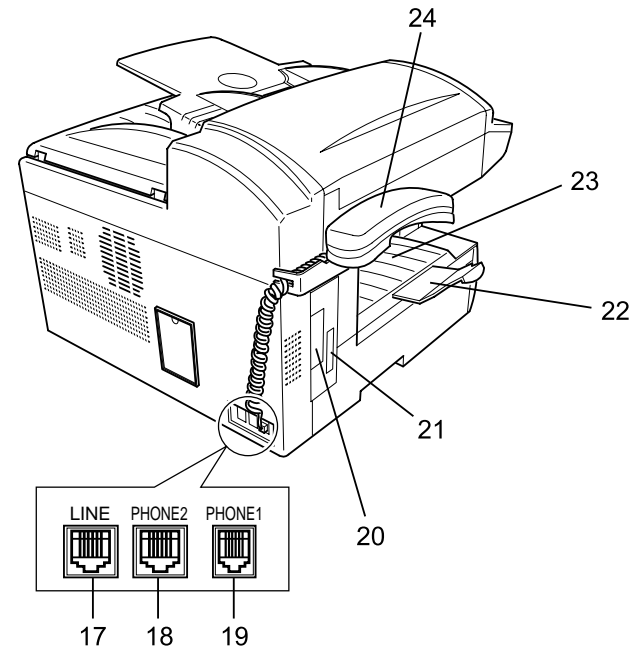

- 17 LINE jack** — Where you plug in the telephone line cord. The other end of the cord plugs into a wall telephone jack.
- 18 PHONE2 jack** — If you connect a second telephone to your machine, this is where you plug in the cord.
- 19 PHONE1 jack** — Where you plug in the optional handset.
- 20 PRINTER PARALLEL port (optional)** — Where you plug in the printer cable, when you use the optional printer controller.
- 21 RS-232C interface port (optional)** — Where you plug in the RS-232C cable, when you use the optional RS-232C interface kit.
- 22 Extension paper tray** — Holds up the printout after it emerges.
- 23 Printed document exit** — Where the printout emerges.
- 24 Handset (optional)** — Used for voice communication. This handset is available from your authorized Muratec dealer, and can be added when you purchase the F-360 or as an upgrade afterward.

# Control Panel Overview

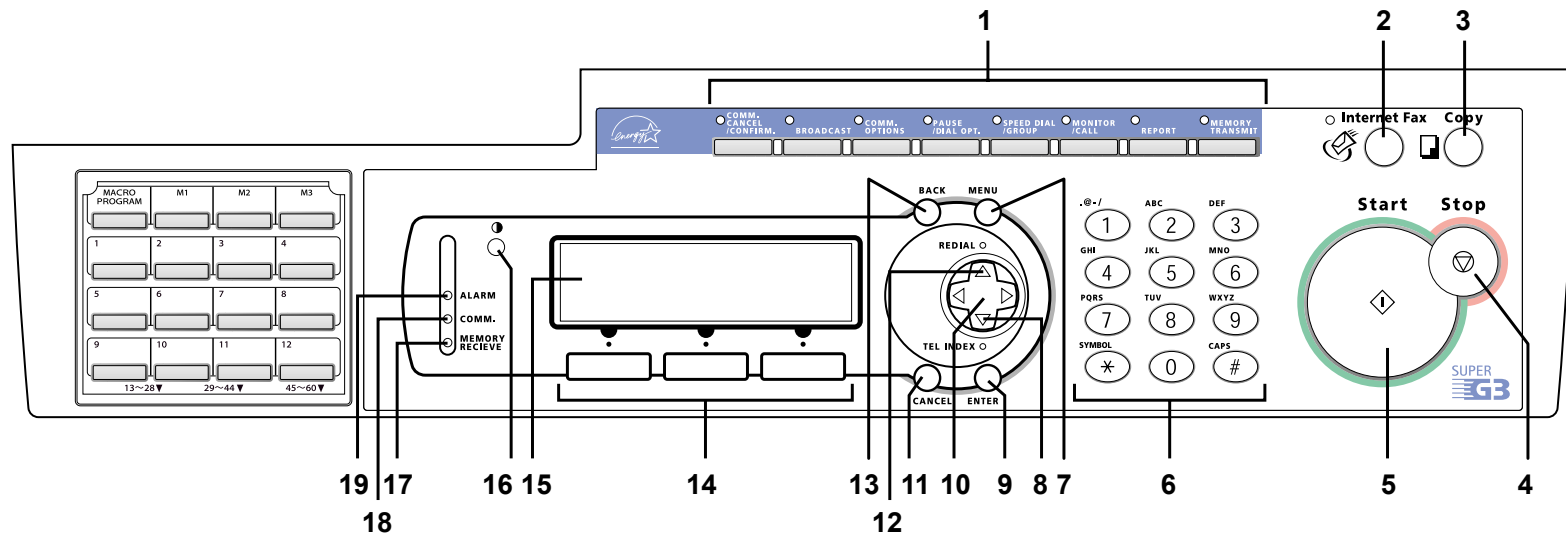

**1 Soft Keys** — Soft Keys are shortcut keys. If the light above any one of these keys glows, that means the setting programmed into that key is active. You can assign some functions into these eight keys as you want. (See page 3.17 for details.) The following functions are assigned at the factory:

Soft Key 1: **COMM.CANCEL/CONFIRM.** — Press to stop the transmission, or to review pending fax commands, the activity journal and out of paper reception.

Soft Key 2: **BROADCAST** — Press to send a broadcast fax (sending the same document to more than one location).

Soft Key 3: **COMM.OPTIONS** — Choose from several fax options – delayed transmission, polling, batch transmission, F-Code transmission, F-Code polling, Fax & Copy and TTI select.

Soft Key 4: **PAUSE/DIAL OPT.** — It produces a special *pause* character which can be useful when dialing long-distance numbers. Or, press this to insert special symbols into telephone numbers.

Soft Key 5: **SPEED DIAL/GROUP** — Press to enter speed-dial numbers or group numbers.

Soft Key 6: **MONITOR/CALL** — Turns the *monitor speaker* on or off. When turned on, it allows you to hear the call you're making. When using this feature, you can only hear the communication taking place. You cannot be heard unless you use a handset (optional). When sending a fax, this key also activates the *call request* feature.

Soft Key 7: **REPORT** — Press to turn the confirmation report feature on or off for the next fax transmission.

Soft Key 8: **MEMORY TRANSMISSION** — Selects which transmission mode your fax machine uses, whether Memory transmission or Real time transmission (see pages 2.2–2.3).

**2 Internet Fax** — Press to deliver the fax message to another computer as an E-mail attachment via the Internet.

**Note:** This function is available only if the optional Internet Fax kit has been installed. Ask your Muratec dealer for details.

**3 Copy** — Press to change from Fax mode to Copy mode.

**Note:** If the optional TWAIN driver has been installed, pressing this key changes from Fax mode to Copy mode to Sacn mode.

**4 Stop** — Stops the current operation and ejects a document from the ADF.

**5 Start** — Press to begin a fax transmission, reception or copying.

**6 Numeric keypad** — Identical to the numeric keys on a regular tone-dialing phone. Use these to dial phone as well as fax numbers, and to enter numbers when you're setting up the machine. Also, you may use these keys to enter the characters when you are setting up the machine.

- 7 MENU** — Any function can be started by first pressing this key and then entering the function number.
- 8 TEL INDEX** — Press ▼ to display *one-touch* and speed-dial entries sorted alphanumerically, as in a telephone directory. (See page 3.8.)
- 9 ENTER** — This key confirms user settings, begins operations, and moves through command levels.
- 10 Cursor Keys**  
◀ ▶ ▲ ▼ — Scrolls (moves) through features and command options as displayed on the LCD.
- 11 CANCEL** — Press to delete characters on the LCD and cancel commands you have entered into the machine.
- 12 REDIAL** — Press ▲ to redial the last number you dialed.
- 13 BACK** — Press to go back to the previous step.
- 14 Select function keys** — These keys correspond to the items at the lower part on the LCD. Press to choose item at the lower part on the LCD.
- 15 Liquid crystal display (LCD)** — Shows the machine's status and lets you see what you're programming into the machine. The display shows 4 lines, 30 characters per line. If the LCD is blank, the machine is off.
- 16 LCD contrast key** — Press to adjust the contrast level of the LCD display.
- 17 MEMORY RECEIVE light** — Glows when the machine is receiving an incoming fax document into its electronic *memory*.
- 18 COMM. light** — Glows when the machine is communicating with another machine.
- 19 ALARM light** — Glows when a problem occurs during fax communication, printing or scanning. The light stays on until the machine prints a *Check Message* report.

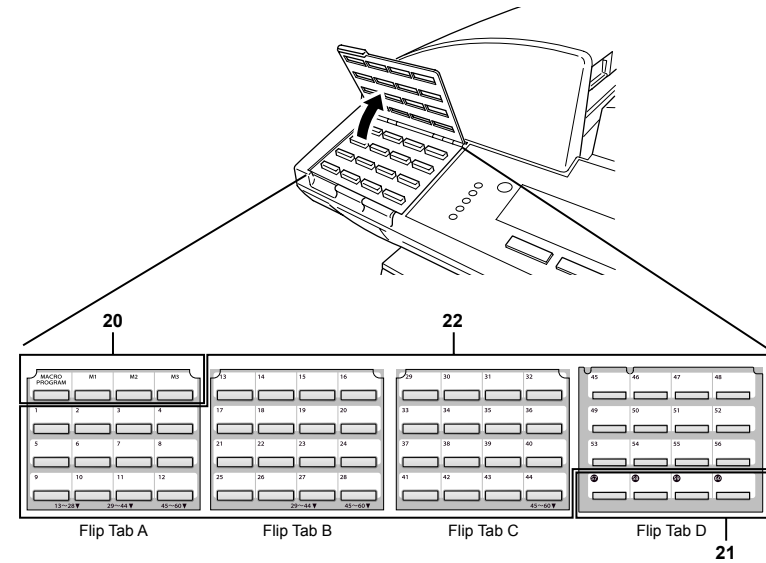

- 20 Macro Keys** — Programming the Macro keys (**M1**, **M2** and **M3**) can reduce many steps of the operation to a simple press of a key. You can “teach” the Macro keys to carry out one of the several operations (see pages 3.18–3.21).
- 21 Programmable One-touch Keys** — The keys labeled **57 to 60** let you teach your machine an advanced multi-step function just once, and then recall the function at any time by pressing one of these keys.
- 22 One-touch Keys** — The keys labeled **01-56** offer one-touch dialing convenience.

# Setting up

## Pick an installation spot

Where should you install your fax machine? The location should be:

- **Clean** — Dust build-up can damage your fax. (However, **do not** use a cover!)
- **In the open** — Allow at least 12 inches of clearance around your machine. Be sure that you **never** cover the machine. Its vents must be able to “breathe.”
- **Away from direct sunlight** — This helps avoid overheating.
- **Dry** — Avoid any location where splatters or sprays (such as from a water fountain) could reach your fax machine.
- **Level, and vibration-free.**
- **Near a phone jack** — Your fax machine uses a standard (modular) telephone jack, also known as an RJ-11.
- **Near an AC power outlet** — The AC power cord is about 6 feet long when stretched to its limit, and the power cord should **never** be stretched to its limit.

## Power tips

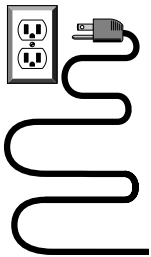

- **Use a standard three-pronged 120 VAC outlet.**
- **Make sure the outlet isn't controlled by a wall switch.** If it is, you'll risk occasional shutoffs to the machine, causing you to lose fax messages.
- **Don't use an outlet which also is supplying power to a large appliance,** such as a refrigerator or air conditioner. Such high-consumption appliances can cause “draw-downs” (temporary drops in the power available for other equipment on the circuit) which could damage your fax machine.
- **Use an electrical surge suppressor,** preferably one which guards both telephone and electrical lines. This device helps to shield your fax machine from damaging high-voltage electrical surges.

## Installing the printing supplies

Your fax prints incoming faxes and copies with a reliable 600 dpi print engine. Your fax requires two types of printing supplies (sometimes also called consumables):

- The *drum cartridge* — It yields 16,000 “normal” letter-sized printouts (see “Specifications,” page A1.2). By “normal,” we’re referring to the amount of text and/or graphics on each page. This is based on an industry-standard test document.
- The *toner cartridge* — It yields 11,000 “normal”, letter-sized printouts (see “Specifications,” page A1.2).

To install these supplies:

**Important:** Gently close the top cover to avoid injury to your hands.

- 1 Open the top cover.

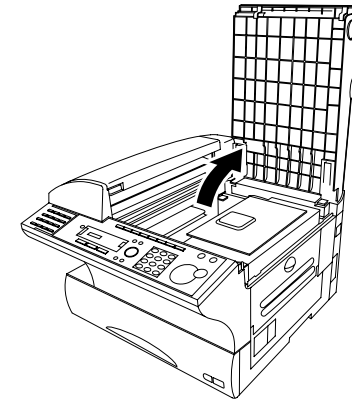

- 2 Pull up the *printer cover release* and open the printer cover.

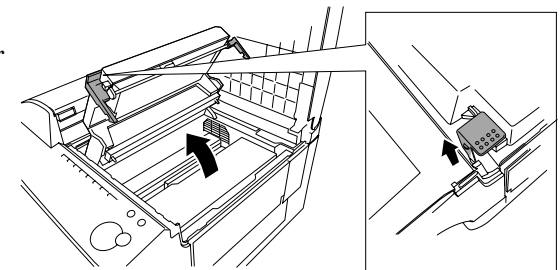



- 3** Unpack a new toner cartridge from its carton. Then, holding the toner cartridge with both hands, slowly shake it to distribute the toner evenly inside the cartridge.

**Note:** Do not touch the roller of the toner cartridge.

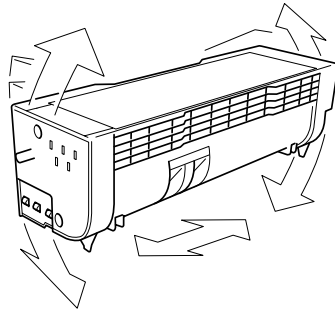

- 4** Gently install the toner cartridge in the printer, making sure the toner cartridge's two pins fit in the slits inside the printer frame.

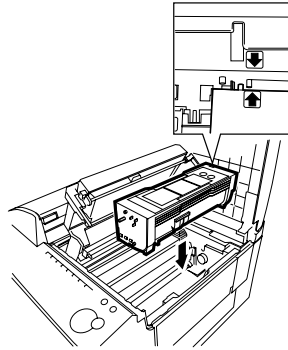

- 5** Unpack the drum cartridge from its carton.

**Note:** Shield the drum cartridge from light, especially strong light. Later, if you have to remove the cartridge from the machine, immediately wrap it in a thick cloth to protect it from light.

- 6** Gently install the drum cartridge in the printer, making sure the drum cartridge's four pins fit in the slits inside the printer frame.

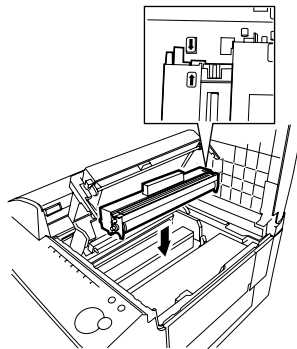

- 7** Gently clean the LED print head using the cleaning paper included in the toner cartridge carton box. For best print quality, you should clean the LED head every time you change the new toner cartridge.

**Note:** Do not use abrasive materials on the LED print head, and do not subject the LED print head to strongly shock.

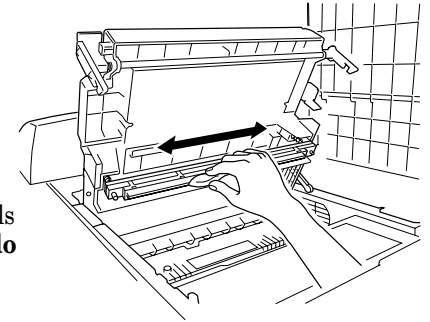

- 8** Gently close the printer cover.

- 9** Close the top cover.

**Note:** The fax machine will not work unless the cover is properly closed.

---

## Attach the paper-handling parts

- 1** Attach the document tray by inserting it into the appropriate holes, as shown.
- 2** Attach the extension paper tray by inserting its two pegs at a slightly upward angle into the appropriate holes, as shown.

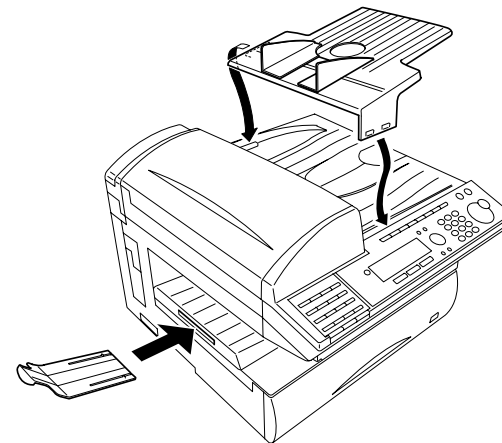

## Plug in and power up

- 1 Plug one end of the telephone line cord into the **LINE** jack on the machine's rear side and the other end into a standard telephone wall jack.
- 2 Plug the non-pronged end of the AC power cord into the AC power cord jack on the right rear side of the machine and the pronged end into a 120 V electrical outlet (preferably on a surge suppressor, as mentioned on page 1.5).

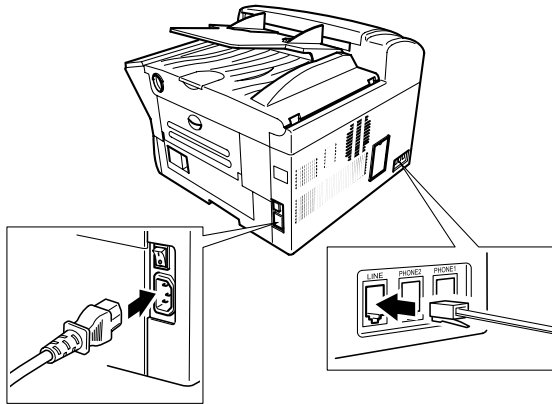

- 3 Use the AC power switch to turn on your machine. The markings are international standards: I means on, O means off.

It will take a few seconds for the machine to warm up. The LCD shows:



When the machine is ready to use (standby mode), you will see:

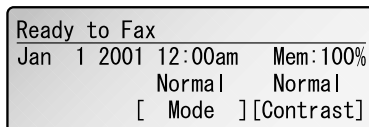

## Adjust the monitor speaker's volume

You can set the volume of the monitor speaker.

- 1 Press **MONITOR/CALL** on the control panel. You now should hear a dial tone. And press ◀ or ▶. The LCD indicates the volume:

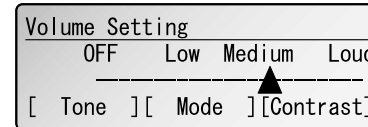

- 2 To turn the volume up, press ▶.  
To turn the volume down, press ◀.
- 3 Press **MONITOR/CALL** again to hang up.

## Loading paper

### Acceptable paper size and cassette capacity

Paper source	Paper type	Paper size	Capacity
Paper cassette	Plain paper* <sup>1</sup>	Letter☐, Legal☐, Half-letter☐	500 sheets
Bypass Tray	Plain paper* <sup>1, *2</sup>	Letter☐, Legal☐, Half-letter☐, A4☐, A5☐☐, A6☐, F4☐, Executive☐, Custom-sized* <sup>3</sup>	50 sheets
	Envelopes* <sup>2</sup>	DL☐, CM10☐, Monarch☐	1 sheet
	Postcard* <sup>2</sup>	3.9" × 5.8" (100 × 148mm)☐	20 sheets
	Transparency* <sup>4</sup>	Letter☐	20 sheets

\*<sup>1</sup> Paper weight: 60 – 90 g/m<sup>2</sup>

\*<sup>2</sup> A4, A5, A6, F4, Executive, DL, CM10, Monarch, Postcard, Custom-sized paper and Transparency can be used only if the optional Printer Controller is attached.

\*<sup>3</sup> (3.8 – 8.5) inches × (5.5 – 14.0) inches (Width × Length)

\*<sup>4</sup> We recommend: 3M PP2500 for laser printers or equivalent

**Note:** Do not use any paper which has been creased, wrinkled or has absorbed any moisture.

## Loading paper in paper cassette

Before you load paper, note the following:

- After you load paper in fax's cassette, you must "tell" your machine what size paper you loaded: letter-, legal- or half letter-sized. You can do this by the "Setting of the paper size" operation. (See pg 1.9.)

**Note:** If you will be using letter-sized paper, there's no need to adjust the cassette; your machine is initially set for Letter-sized paper. Simply attach the LTR sticker to the outside of the paper cassette.

- 1 Open the paper cassette from the front of your machine by gently pulling it toward you.

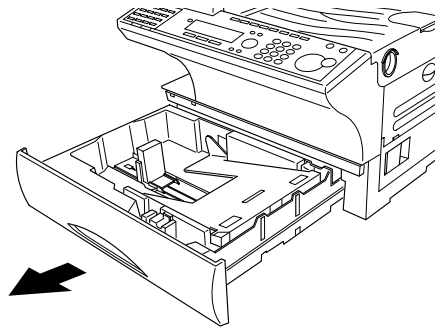

- 2 While pressing the release lever, slide the paper length guide to select the paper size you want to use.

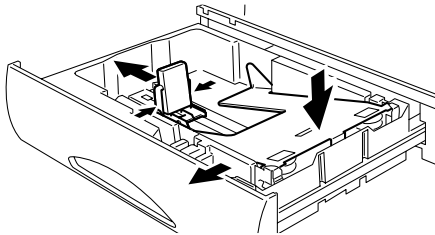

- 3 Press down the paper lifting plate.

- 4 Insert the paper into the cassette.
  - Before you insert paper in the cassette, stack it so the leading edge and sides of the paper are even.
  - **Do not** stack the paper over the limit mark inside of the cassette.
  - Place the edges of the top sheet under the metal tabs on the cassette's left and right side.

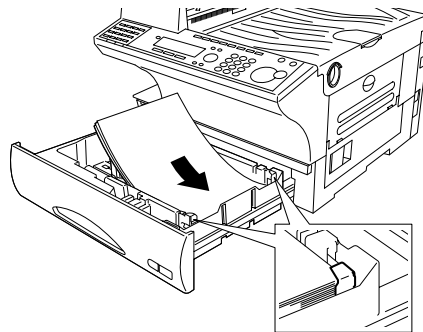

- 5 Adjust the paper guides to fit the size of paper.

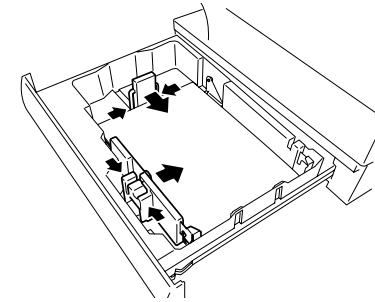

- 6 Gently push the paper cassette back into its original (closed) position. You'll feel a click when it's properly in place.
- 7 Attach the paper size sticker on the cassette's front.

**Helpful Tip:** The paper level indicator on the front paper cassette lets you see how much paper is in the cassette without your having to open the cassette. When you see the paper level indicator drop (i. e., show more blue area), make sure you have a supply of paper nearby. Then, when you see the "Please Supply Paper" message on the display, you'll be ready to refill the cassette.

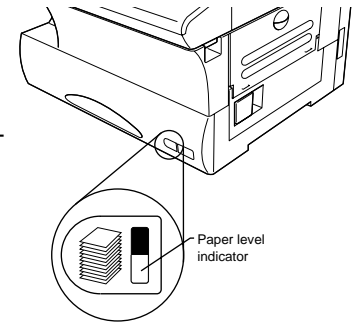

**Important:** To avoid paper jams, do not refill this paper cassette without first removing all of any paper which may remain in it. In other words, do not just add sheets to an already-loaded stack.

## Setting of the Paper Size

Default setting: Letter-sized paper

When you change the size of paper in the paper cassette, you must also change the paper size setting, as shown below.

- 1 Press **MENU**, **2**, **1**, **0**, **1**, **ENTER**. The LCD shows:

```

01. Cassette Size
Exit
1st Cassette :Letter
Bypass Tray  :Letter
  
```

- 2 To select the paper size in the 1st cassette, select **"1st Cassette"** using the cursor key and then press **ENTER**. The LCD will show:

```

1st Cassette
Letter
Legal
H. LTR
  
```

- 3 Use **▼** or **▲** to select the paper size, Letter, Legal or Half-letter, and then press **ENTER** to save the setting.
- 4 To set the default paper size that is displayed when you set the paper on the bypass tray, select **"Bypass Tray"** and then press **ENTER**. The LCD will show:

```

Bypass Tray
Letter OHP
Legal
H. LTR
  
```

- 5 Using the cursor key, select the paper size, Letter, Legal, Half-letter or OHP, and then press **ENTER** to save the setting.

**Note:** "OHP" appears only when the "Bypass Tray" is selected.

- 6 Select **"Exit"** and then press **ENTER** to exit this mode.

```

01. Cassette Size
Exit
1st Cassette :Letter
Bypass Tray  :Letter
  
```

## Loading paper in bypass tray

When you need to use a size of paper not currently loaded in your machine's paper cassette(s), or when you want to use a special type of paper (such as transparency film), use the bypass tray.

- 1 Open the bypass tray on the right side of your machine.

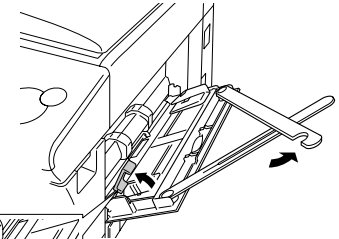

- 2 Pull out the hopper of the bypass tray and raise the flapper release lever.

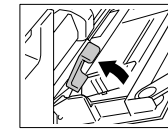

- 3 Place the paper on the bypass tray. Adjust the paper guide to fit the paper and insert the paper until it comes to a stop. Then lower the flapper release lever.

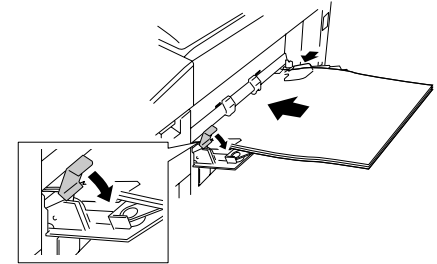

- 4 When you load the paper on the bypass tray, the LCD will show the primary paper size you've set. (See "Setting of the paper size," left column.)

```

Bypass Tray
Letter OHP
Legal
H. LTR
  
```

- 5 Use the cursor key to select the paper size you set on the bypass tray. Then press **ENTER**.







**Note:** If you use transparency film, select "OHP".

**Note:** If you have set the Letter, Legal, Half-letter sized paper in the bypass tray, the machine will use them when it runs out of the paper in the paper cassette during the fax reception.

# Operating tips

## Symbol and terms

In this manual, the following symbols and terms are used, make sure you know what they mean.

 <b>CAUTION</b>	This symbol indicates how to avoid personal injury.
<b>Important:</b>	This instruction describes conditions or incorrect operations that could cause damage to your machine.
<b>Note:</b>	A note describes helpful hints, restrictions, or how to avoid difficulties.
[ ]	Keys that appear at the lower parts on the LCD. To press this key, use the select function key.
“ ”	Items that appear on the LCD.
<b>BOLD WORDS</b>	Keys built into the machine's control panel.
LCD	The Liquid Crystal Display. It shows the machine's status, error messages and function menu, etc.
Document	“Document” is the original sheet(s) of paper you send or copy on your machine.
Paper	“Paper” is the recording paper for printing.
 , 	Shows the direction of the document or paper.
<b>MENU</b>	Any function can be started by first pressing the <b>MENU</b> key.
Cursor key	Press  ,  ,  or  to select items in a menu or move the cursor.

## How to operate the machine

Most settings and functions are started by first pressing the **MENU** key. Then press four-digit numbers to select the function. In this manual, we explain the operation with *short-cut* operations (for example, we will say, “press **MENU, 1, 1, 0, 1.**”).

*To press:* **0** (zero), **1, 2, 3, 4, 5, 6, 7, 8, 9, #** or **\***  
*Use:* The numeric keypad.

Here's an example. If we say “press **MENU, 1, 1, 0, 1, ENTER**” ...

```

... you'd press  MENU key
... then      1
... then      1
... then      0 (the numeric key zero)
... then      1
... and then  ENTER

```

**Note:** Even though our example above includes commas, **do not** enter them into the fax machine. Those characters appear in our instructions to separate one number from the other. They do not need to be entered into your fax machine.

There is a function (broadcasting) which requires commas to be entered, but there is a special way to enter them. We'll explain this process later.

## Searching the functions using the cursor key

Even if you don't remember the exact commands needed for an operation, you can search for and enter almost all of your unit's functions using the **MENU** key, **Cursor key** and the **ENTER** key.

**Note:** You can also search for any function with the *function table* (see page 1.13).  
Keep a copy of this table nearby for reference.

To search and enter the function settings:

- 1 Press **MENU**.
- 2 Search the level one function groups using ▼ or ▲ until your desired item appears.
- 3 After you find the level one function item you want to program, press ► to go to the level two function groups.
- 4 Search the level two function groups using ▼ or ▲ until your desired item appears.
- 5 After you find the level two function item you want to program, press ► to go to the level three function groups .
- 6 Search the level three function groups using ▼ or ▲ until your desired function appears.
- 7 Press **ENTER** to entry the function setting.

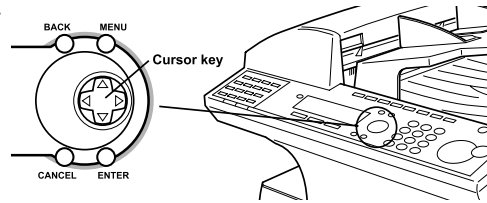

**Note:** You can go back to previous level function groups by pressing ◀ before you have entered the level three function by pressing **ENTER**. If you want to go back to previous level function group after entering the level three function, press **BACK**.

**Note:** Stop the operation at any time by pressing **STOP**.

## Entering characters

Some settings give you a chance to enter characters; for your TTI, remote fax's name or others. To enter letters or other characters, use the following guidelines:

### Using numeric keypad to enter characters

You can enter 40 letters, digits or symbols (and space) using the numeric keypad as shown in the character table below.

Pressing the **2** numeric key once, for example, will enter an "A". Pressing **2** twice, will enter a "B". If you want to enter "LA", for example, you would press **5, 5, 5, 2**.

When you want to enter two characters that share the same numeric key ("D" and "E", for example), press **▶** to move the cursor to the right after you enter the first letter. For example, if you want to enter "ABC": press **2, ▶, 2, 2, ▶, 2, 2, 2**.

Character Table

Numeric keypad	Character
①	1 . @ - _ , / : & ' □ ! ?
ABC ②	A B C 2
DEF ③	D E F 3
GHI ④	G H I 4
JKL ⑤	J K L 5
MNO ⑥	M N O 6
PQRS ⑦	P Q R S 7
TUV ⑧	T U V 8
WXYZ ⑨	W X Y Z 9
⑩	0
SYMBOL ✳	Special Characters
CAPS #	Caps Lock

Note: □ means space.

### Canceling characters

If you entered an incorrect letter or digit, press **CANCEL** to erase to the left. To change just one character in name and/or digit, press **◀** or **▶** to move the cursor to that character or digit. Then press **CANCEL** to erase it. Re-enter the character or digit correctly.

### To change upper/lower case

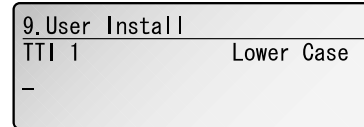

Press **#(CAPS)** key to toggle upper case and lower case.

The word "Lower" means the machine will enter only lower-case letters.

To type a upper-case letter, press **#(CAPS)** key.

The LCD changes to:

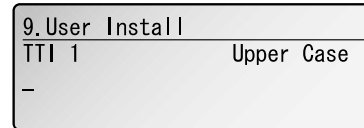

This means the machine will enter upper-case letters.

To switch back for lower-case entries, press **#(CAPS)** key again.

### Entering the special characters

You can also enter special characters or symbols.

- 1 When the machine prompts you to enter a name, press **\*** key.  
The LCD changes to:

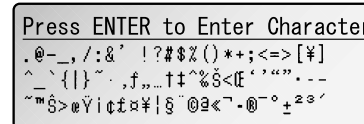

- 2 Select the character you want to enter using **▼**, **▲**, **◀** or **▶** of cursor key.
- 3 To enter the character, press **ENTER** key.
- 4 If you want to enter other character, repeat steps 1–3.  
Otherwise, go to next step.
- 5 Press **ENTER** to save the name.

# Function table

**Note:** Your machine can print a function list. It lists the functions available on your fax machine and the keystrokes needed to complete them.  
To print a function list, press **MENU, 5, 1, 0, 1**.

Level one function	Level two function	Level three function	Summary of setting	Default setting	Page
1. Autodial Entries	1.One-touch Dial	01.Enter One-Touch (Max. 56 locations.)	Select one-touch key and register the fax dial numbers and names on one-touch dial keys. If you register the name, you can use the telephone index feature.	—	3.2
		02.Erase One-Touch	Erase the registration in a one-touch key.	—	3.2
	2.Speed Dial	01.Enter Speed Dial (Max. 244 locations.)	Select speed-dial number and register the fax dial numbers and names as Speed-Dial numbers. If you register the name, you can use the telephone index feature.	—	3.4
		02.Erase Speed Dial	Erase the registration in a speed-dial number.	—	3.4
	3.Group Dial	01.Enter Group Dial (Max. 32 group.)	Select group number and register the one-touch dial or speed-dial numbers you want to group.	—	3.6
		02.Erase Group Dial	Erase the registration in a group number.	—	3.7
2. User Settings	1.Machine Settings	01.Cassette Size	Set the size of paper in the paper cassette.	Letter	1.9
		02.Protect Passcode	Enter the protection passcode for using the security features.	—	3.46
		03.Soft Key	Program to turn on or off the function by pressing this key. Soft key 1: COMM. CANCEL / CONFIRM. Soft key 5: SPEED DIAL / GROUP Soft key 2: BROADCAST Soft key 6: MONITOR / CALL Soft key 3: COMM. OPTIONS Soft key 7: REPORT Soft key 4: PAUSE / DIAL OPT. Soft key 8: MEMORY TRANSMIT	See left.	3.17
		04.Silent Mode	Mute your machine.	Off	4.8
		05.Sleep Mode	Conserve power.	On	4.9
		06.Fax & Copy	Make a copy of your document each time it transmit.	Off	3.21
		07.Date & Time	Enter the current date and time.	—	4.9
		08.Paper Source	Select paper source (paper cassette and bypass tray) for fax reception or copying.	For Fax / Copy	4.9
		09.Service Mode	For technical support. Do not turn this setting to on unless an authorized technician asks you to do so.	Off	—
		10.2-Bin Tray*1	Select the paper tray for delivery. • Copy exit • Received fax document exit • List exit • PC-Fax print exit*2	Lower tray Upper tray Upper tray Upper tray	4.9

\*1: This option appears only if the optional 2-Bin tray has been installed.

\*2: This option appears only if the optional RS-232C interface has been installed.



Level one function	Level two function	Level three function	Summary of setting	Default setting	Page
2. User Settings	2.Fax Settings	01.Scan Parameters	You can set the following settings for send fax message. <ul style="list-style-type: none"> <li>• Primary resolution mode</li> <li>• Primary contrast mode</li> <li>• Scanning width limit</li> </ul>	Normal Normal B4	4.1
		02.Print Parameters	You can set the following settings for receive fax message. <ul style="list-style-type: none"> <li>• Reduction rate</li> <li>• Reduction margin</li> <li>• Half-page reception</li> </ul>	Auto 40 mm Off	4.3
		03.Number of Rings	Number of rings before your machine answers.	2 times	4.4
		04.Redial	Number of times and interval for automatic fax redialing.	2 times 1 minute	4.5
		05.Dialing Pause	Dialing pause length.	2 seconds	4.5
		06.Memory Transmission	On/Off setting for Memory transmission.	On	4.2
		07.Quick Memory Tx	On/Off setting for Quick Memory transmission.	On	4.2
		08.TTI Transmission	On/Off setting for sending your TTI.	On	4.2
		09.ECM Mode	On/Off setting for ECM mode.	On	4.2
		10.Block Junk Fax	Reject the fax reception from unauthorized incoming faxes.	Off	3.50
		11.Security Rx	Keep all received fax messages in memory and after print them.	Off	3.46
		12.Separator Page	Partition each received documents by inserting the separator page.	Off	3.24
		13.Rotate Rx	On/Off setting for Rotate Rx.	Off	4.4
		14.PIN Mode	Prevent unauthorized long-distance calls.	Off	3.48
		15.DRD	Set the ring pattern to use with phone company's Distinctive Ring service.	Off	3.25
	3.Copy Settings	01.Scan Parameters	You can set the following settings for copying. <ul style="list-style-type: none"> <li>• Primary resolution mode</li> <li>• Primary contrast mode</li> <li>• Scanning width limit</li> </ul>	Fine Normal B4	4.6
			02.Print Parameters	You can set the following settings for copying. <ul style="list-style-type: none"> <li>• Reduction rate</li> <li>• Reduction margin</li> <li>• Bypass Tray priority</li> </ul>	100% 24 mm No
	4.Printer Settings* <sup>3</sup>	01.TCP/IP	Enter the IP Address, Subnet mask and Gate way address.	—	—
	5.Scanner Settings* <sup>4</sup>	01.Scan Parameter	Enter the scanning parameters.	—	—
		02.Auto Reset	Set the time (minutes) for resetting the scan parameters and . returning to the Fax mode.	10 minutes	—

\*3: This option appears only if the optional NIC (network interface card) has been installed.

\*4: This option appears only if the optional printer controller has been installed. For details see the operating instructions included with the printer controller kit.

Level one function	Level two function	Level three function	Summary of setting	Default setting	Page
3. Other Settings	1.Journal & Reports	01.Journal Auto Print	Print the Activity journal automatically after 100 transactions.	Off	3.22
		02.Journal Line Up	Change the printing order of the activity journal.	Off	3.23
		03.Report Auto Print	Print the TCR automatically at every transmission.	Off	3.23
	2.Cover Page	01.Set Cover Page	On/Off setting for sending the Cover page.	Off	3.25
		02.Cover Page Message	Enter your message for the cover page.	—	3.25
	3.Department Code	01.Department Code Protect	Protection for department code settings.	Off	3.53
		02.Enter Department Code	Register the Department code.	—	3.52
		03.Department Setting	On/Off setting for Department code activation.	Off	3.52
		04.Erase Department TimeList	Clear the total counts of each department code.	—	3.53
	4.Program One-Touch	01.Set P One-touch	Program several operations for a function you frequently use. This key can reduce several steps to a simple press of a key.	—	3.38
		02.Erase P One-touch	Erase the programming in a programmable one-touch key.	—	3.45
	5.F-Code Box	01.Set F-Code Box	Create the F-Code box.	—	3.28
		02.Erase F-Code Box	Erase an empty F-Code box.	—	3.35
	6.Batch Tx	01.Set Batch Box	Create the Batch box.	—	3.12
		02.Erase Batch Box	Erase an empty batch box.	—	3.14
	7.Scan Box* <sup>4</sup>	01.Set Scan Box	Create the Scan box.	—	—
		02.Erase Scan Box	Erase an empty scan box.	—	—
	8.Internet Fax* <sup>5</sup>	01.TCP/IP	Set the TCP/IP address.	—	—
		02.MAC Address	Enter the Media Access Control Address for network card.	—	—
		03.Default Relay	Setting of relay box.	—	—
4. Doc. Management	1.Store Document	01.Polling Document	Store the document to be retrieved by other fax machine.	—	3.15
		02.F-Code Document	Store the document to be retrieved by other F-Code compatible fax machine.	—	3.32
	2.Erase Document	01.Polling Document	Erase stored document for polling transmission.	—	3.16
		02.F-Code Document	Erase stored document in the F-Code box.	—	3.33
		03.Batch Tx Document	Erase stored document in the Batch box.	—	3.14
		04.Scan Box Document* <sup>4</sup>	Erase stored document in the Scan box.	—	—
	3.Print Document	01.Polling Document	Print the stored document for polling transmission.	—	3.16
		02.F-Code Document	Print the stored document in the F-Code box.	—	3.33, 3.34
		03.Batch Tx Document	Print the stored document in the Batch box.	—	3.13

\*4: This option appears only if the optional printer controller has been installed. For details see the operating instructions included with the printer controller kit.

\*5: This option appears only if the optional Internet fax kit has been installed. For details see the operating instructions included with the Internet fax kit.

Level one function	Level two function	Level three function	Summary of setting	Default setting	Page
4. Doc. Management	3.Print Document	04.Security Rx Doc.	Print the fax received document during Security reception (and return to your machine to normal reception mode until the next time).	—	3.47
		05.Comm. Stored Document	Print the stored document for delayed transmission.	—	2.7
5.Print	1.List Print	01.Function List	Print a list of your machine's functions.	—	1.13
		02.User Settings	Print a list of your machine settings.	—	4.10
		03.Journal	Print the activity journal manually.	—	3.22
		04.Commands List	Print a list of the delayed commands.	—	2.7
		05.One-Touch List	Print a list of the one-touch dial keys.	—	3.3
		06.Speed Dial List	Print a list of the speed-dial numbers.	—	3.5
		07.Group List	Print a list of the group numbers.	—	3.7
		08.Block Junk Fax List	Print a list of the blocked numbers.	—	3.51
		09.Cover Page	Print a cover page.	—	3.25
		10.Dept. Time List	Print a total communication time and printed pages of each department code.	—	3.53
		11.P One-Touch List	Print a list of the programmable one-touch keys.	—	3.45
		12.F-Code Box List	Print a list of F-Code boxes.	—	3.32
		13.F-Code Doc. List	Print a list of the document stored in the F-Code boxes.	—	3.32
		14.Batch Box List	Print a list of Batch boxes.	—	3.13
		15.Batch Doc. List	Print a list of the document stored in the batch boxes.	—	3.13
		16.Macros List	Print a list of Macro keys.	—	3.21
		17.Scan Box List* <sup>4</sup>	Print a list of Scan boxes.	—	—
	2.Printer Function* <sup>4</sup>	01.Status Page	Print all the status and configuration of the printer.	—	—
		02.Font List	Print the list of all PCL fonts currently installed in the printer.	—	—
		03.NIC Status* <sup>3</sup>	Print the NIC (network interface card) settings.	—	—
6. PC-FAX Commands* <sup>2</sup>	1.PC-FAX	01.PC-FAX Scan	Scanning a document into the PC.	—	—
		02.PC-FAX Initial	Initializing your machine.	—	—
		03.Set RS-232C	Setting of the RS-232C parameters.	—	—

\*2: This option appears only if the optional RS-232C interface has been installed.

\*3: This option appears only if the optional NIC (network interface card) has been installed.

\*4: This option appears only if the optional printer controller has been installed. For details see the operating instructions included with the printer controller kit.

Level one function	Level two function	Level three function	Summary of setting	Default setting	Page
9. User Install			Set-up the following settings: <ul style="list-style-type: none"> <li>• Language on the LCD and Lists</li> <li>• Current Day and Time</li> <li>• Automatically Daylight saving time</li> <li>• Fax reception mode</li> <li>• Phone dialing type</li> <li>• Subscriber ID (your fax phone number)</li> <li>• Your TTI (your name)</li> <li>• TTI select</li> <li>• Time for the machine to enter the sleep mode</li> </ul>	English — Off Fax Ready Tone — — — 5 minutes	1.18

# EasyStart (Initial settings)

EasyStart software is already installed on your Muratec fax machine. It guides you through the process of entering the following settings. These settings you make here can always be changed later.

- Language on the LCD and Lists
- Current Day and Time
- Automatically Daylight saving time
- Fax reception mode
- Phone dialing type
- Subscriber ID (your fax phone number)
- Your TTI (your name)
- TTI select
- Time for the machine to enter the sleep mode

---

## Getting started

Determine the following before you go any further:

- 1 The type of dialing** your telephone system requires — Choose either *Tone* or *Pulse* (rotary) dialing.
- 2 The name and fax number you want to appear on your faxes** — Every fax page you send arrives at the receiving machine with a single line of text at the very top of the page. This text lists a *name* (called the *Transmit Terminal Identifier (TTI)*) and a *fax number* (called the *Subscriber ID*). The TTI cannot be longer than *22 characters*.

## Clearing stored settings

Before using EasyStart, clear your machine's built-in *user data memory*. This ensures the memory will hold only *your* settings.

**Important:** After you use EasyStart, *do not* clear the memory again unless an authorized technician asks you to do so.

To clear the machine's memory:

- 1** Press **MENU, \*, 0, 2**. The LCD now asks if you want to clear the memory:

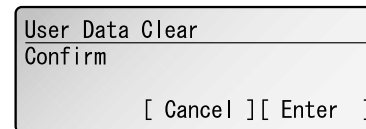

**Note:** If you *don't* want to clear the memory, just press **CANCEL**.

- 2** If you *do* want to clear the memory, press **ENTER**.

---

## Entering initial settings

**Important:** If you press **STOP** during EasyStart, your fax machine returns to *standby mode* (its normal condition). But it will keep the settings you saved by pressing **ENTER** as described in these instructions.

- 1** To start EasyStart software, press **MENU, 9, ENTER**. The LCD shows:

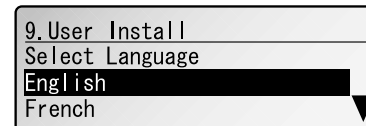

- 2** Using the cursor key, select the language you want.
- 3** Press **ENTER** to save the language setting and continue EasyStart.

- 4 The LCD now shows the current calendar/clock setting, with a *cursor* appearing on the first digit.

```
9.User Install
-----
Enter Current Date and Time
01/01 2001 00:00
```

- 5 Use the numeric keypad to enter the *correct date and time*, using a *MMDDYY* format for the *date* and *24-hour* format for the *time*. For instance, to set 2:30 PM on September 27, 2001, press **0 9 2 7 0 1 1 4 3 0**, which results in:

```
9.User Install
-----
Enter Current Date and Time
09/27 2001 14:30
```

**Note:** Your fax machine automatically inserts the spaces and date-slash. All you have to do is enter the digits.

To change a digit, press ◀ to move the cursor left, or ▶ to move it right. Then enter the correct digit.

- 6 Press **ENTER** to save the clock setting and continue.
- 7 The LCD now asks if you want to set the calendar/clock to automatically recognize daylight saving time (DST).

```
9.User Install
-----
Daylight Saving
ON
OFF
```

When the setting is *ON*, your machine automatically recognizes DST at 2 AM on the appropriate switchover Sundays each year.  
When the setting is *OFF*, no automatic change will occur.

- 8 Using the cursor key, select the mode you want.
- 9 Press **ENTER** to save the setting and continue.
- 10 The LCD now shows the machine's current reception mode.

```
9.User Install
-----
Select Rx Mode
Fax Ready
Tel/Fax Ready
```

- 11 For now, select *Fax Ready*. (This setting can always be changed. We'll discuss reception modes further on pages 2.8–2.9.)

- 12 Press **ENTER** to save the setting and continue.

- 13 The LCD now asks you to enter the type of dialing needed for the fax machine, either *tone* or *pulse*:

```
9.User Install
-----
Select Dialing Type
Tone
Pulse
```

- 14 Using the cursor key, select the mode you want.

- 15 Press **ENTER** to save the setting and continue.

- 16 The LCD now asks you to enter your fax number as you want it to appear on other fax machines' displays or printouts. The fax industry term for this number is *Subscriber ID*.

```
9.User Install
-----
Enter Your Fax Number
- [ + ] [ - ]
```

- 17 Use the numeric keypad to enter the fax number. The number may contain up to 20 characters (numbers and dashes).

**Note:** To insert a dash, as shown here, press [ - ]. To insert “ + ” before the country number for the overseas call, press [ + ].

**Note:** If you make a mistake, press **CANCEL** to erase to the left. To change just one number, press ◀ to move left, or ▶ to move right. Press **CANCEL** to erase the number. Then re-enter the fax number correctly.

- 18 Press **ENTER** to save the number and continue.

- 19 The LCD now asks you to enter the name you want to appear at the top of faxes you send. You can enter three of TTI. Select TTI 1, 2 or 3 using the cursor key.

```
9.User Install
-----
Exit
TTI 1 :Not Stored
TTI 2 :Not Stored
```

**20** Press **ENTER**. The LCD will show:

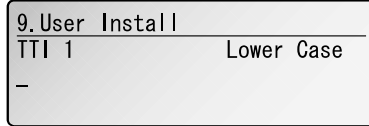

**21** Use the numeric keypad to enter characters. The name may be up to 22 characters in length. Regarding entering characters, see page 1.12.

**Note:** If you make a mistake, press **CANCEL** to erase to the left. To change just one character in the name, move the cursor by cursor key. Press **CANCEL** to erase the character. Then re-enter the character correctly.

**22** Press **ENTER** to save the TTI.  
If you *do* want to set or change *another* TTI, go back to step 19.  
If you *do not* want to set or change *another* TTI, proceed to step 23.

**23** Select "**Exit**" and then press **ENTER** and continue.

**24** The LCD now asks you to set the usual TTI.  
Select the TTI you want to appear usually at the top of faxes you send using the cursor key.

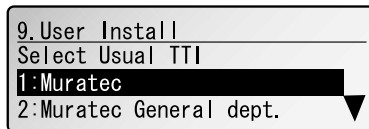

**25** Press **ENTER** to save the setting and continue.

**26** The LCD now asks you to enter the time for the sleep mode. Your machine will now automatically enter sleep mode after your selected idle time has elapsed.

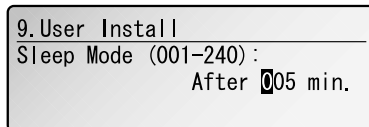

**27** Enter the time (in minutes) using the numeric keypad.

**28** Press **ENTER** to save the setting. Your machine will return to standby mode.

*This page intentionally blank.*



# Basic Operations

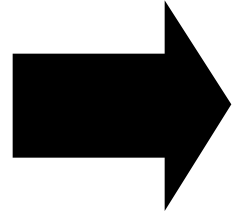

*This chapter describes the basic operation of the transmission, reception and copying*

Sending faxes .....	2.1
Receiving faxes .....	2.8
Making copies .....	2.10
Using your fax machine as a phone .....	2.12

# Sending faxes

## Guidelines

Before you begin the fax sending, please read the following guidelines.

### Acceptable document sizes

You can set up to 80 sheets of letter-sized document in the ADF at one time. However, it's possible to fax a piece of paper as small as a notepad sheet or one up to three feet long.

The acceptable dimensions (width × length) are:

SINGLE-SHEET	MULTIPLE-SHEET
Maximum: 11" × 35.4"	Maximum: 10.1" × 14.3"
Minimum: 4.7" × 3.9"	Minimum: 8.5" × 5.5"

### Things **not** to put in your fax

To avoid paper jams and damage to your machine, **don't insert:**

- Folded, curled, torn, wrinkled or very thin pages
- Documents with staples, glue, tape, paper clips or still-wet correction fluid
- "Sticky notes" (or documents with "sticky notes" attached)
- Cardboard, newspaper or fabric
- Pages with duplicating carbon on either side
- Credit cards or any small, thick items
- OHP transparency film

### How to set the document

- 1 Insert your document(s) **face up, top edge first**. If you're sending a multi-page documents, "fan" the pages slightly.
- 2 Adjust the document width guide to fit your documents.

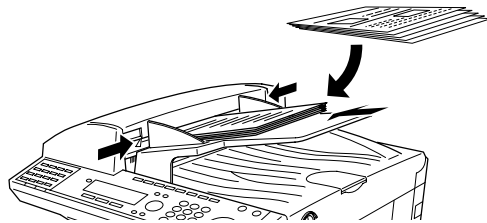

## Resolution, grayscale and contrast

### Reviewing resolution and grayscale:

- **Normal resolution** is suitable for most typed documents and simple drawings.
- **Fine resolution** is ideal for maps, moderately complicated drawings, floorplans or handwritten documents.
- **Superfine resolution** ("S-fine" on the LCD) reproduces the detail of extremely complicated drawings or line art.
- **Grayscale mode** ("Gray" on the LCD) captures shades in photos and drawings.

**Note:** If you send a fax in superfine, certain fax models (especially older, non-Muratec models) receive it only in fine mode. However, you can send a fax in grayscale mode to virtually *any* fax machine currently in use.

To change the resolution setting, press **[Mode]** repeatedly. It will toggle Normal, Fine, S-Fine and Gray.

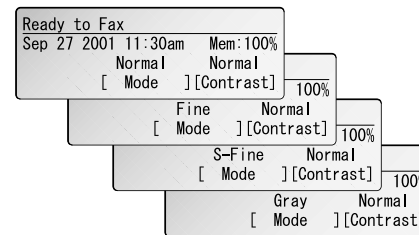

### Reviewing contrast

Setting the contrast allows you to compensate for any excessive lightness or darkness, as the case may be, of document pages you are sending or copying.

To change the contrast setting, press **[Contrast]** repeatedly. It will toggle Normal, Light and Dark.

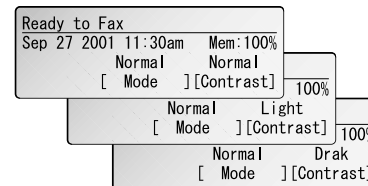

**Note:** To avoid confusing the Light and Dark settings, just remember — "Light lightens" and "Dark darkens" — to keep it straight.

## Mixing resolution and contrast in a multiple page

When you send a document with more than one page, you can select different resolutions and contrasts for each page.

Insert your documents, select resolution and contrast for the first page, dial and press **START**. Before starting to scan the next page, select resolution and contrast for the next page.

## Dialing pause

Some long-distance systems require dialing pauses, and pauses can also be useful when you're dialing through special telephone exchanges.

To insert a *pause*, just press **PAUSE/DIAL OPT.** (The pause character (-/) will appear on the LCD.) Each pause entered lasts for a factory-set two seconds.

For example, pressing **9, PAUSE/DIAL OPT., 0123456789** dials 9 [2-second pause] 0 1 2 3 4 5 6 7 8 9.

**Note:** You can change the dialing pause length within 2 to 10 seconds. (see "Changing the dialing pause length," page 4.5.)

## Potential problems with call-waiting and voice mail

Telephone call-waiting signals can stop fax transmission and reception. And any service — such as voice mail — which may intercept your calls can keep your fax machine from receiving fax calls.

If you use only one line for both phone and fax, consult your telephone company to see how you can temporarily disable call-waiting or voice mail while using the fax machine.

---

## Memory transmission

Your fax machine has a great memory! Take advantage of it, and you could:

**Save Time.** By using your fax machine's memory, you won't have to wait for your machine while it completes the transmission. Simply scan your document into your machine's memory, and you can walk away with your original in hand.

**Save Money.** If you're transmitting to another memory-equipped fax machine, your machine will send the document directly into the other machine's memory and hang up. (The receiving machine then prints out your message from its memory after the call has ended.) This cuts your actual on-line time to a minimum.

**Save Even More Money.** Set up a delayed transmission (see page 3.11) to send your document after hours. This allows you to take advantage of cheaper line charges, saving you even more money.

**Note:** Some documents use up memory more quickly than others. They include documents with many pages and those with many dark areas. *When the machine's memory is full, it can only transmit through the document feeder.*

The memory transmission is *On* for default setting. However, you can turn it off for the default. (See page 4.2.)

**Note:** You can override the default setting of memory transmission for only one transmission by pressing **MEMORY TRANSMISSION** before you send your document. After completing the communication, your machine will return to the default setting.

---

## Quick memory transmission

Using Quick Memory transmission can save you time over standard memory transmissions.

For a *normal memory transmission*, your fax: (1) scans your entire document into memory, (2) dials the other fax machine, then (3) transmits the document.

But with *Quick Memory transmission*, your machine doesn't wait to scan all pages into memory before dialing. After it scans the first page of your document, your machine dials the call. While dialing, connecting and transmitting, your fax machine continues to scan in the remaining pages of the document.

The quick memory transmission is *On* for default setting. However, you can turn off it for the default. (See page 4.2.)

**Important:** To use Quick Memory transmission, the memory transmission feature must be turned on.

---

## Memory overflow message

In normal memory transmission, if you've stored too much information in your machine's memory, a "Memory Overflow" message may appear on the LCD.

When the Quick memory Tx is on:

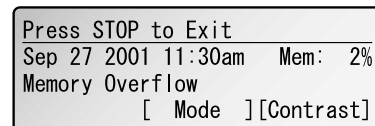

Press STOP to Exit  
Sep 27 2001 11:30am Mem: 2%  
Memory Overflow  
[ Mode ][Contrast]

The "Memory overflow at page xx." message will be printed. Retransmit the document(s) from that page.

**Note:** Your machine will transmit the documents which had been scanned before the memory overflow occurred.

**Note:** If you don't operate your machine within 60 seconds, the machine automatically erase the document stored in the memory during the current operation.

When the Quick memory Tx is off:

```

Memory Overflow
# of Stored Pages: 28
Keep These Pages?
  [ Yes ] [ No ]
  
```

If this message appears, press **[Yes]** to tell your fax to send the document stored in the memory, or press **[No]** to erase all pages stored during the current operation (but not previous operations).

**Note:** If you don't operate your machine within 60 seconds, the machine automatically erase the document stored in the memory during the current operation.

Memory overflow message appears because **(1)** too many pages have been stored in the memory, **or (2)** the pages that are stored have too much information on them for your fax machine to remember.

Dividing a large document into smaller batches will help you avoid this error.

## Real time transmission (Non-memory transmission)

In the following cases, the machine does not use its memory for sending a fax:

- When you turned off the memory transmission
- When you are sending a fax using **MONITOR/CALL** key or optional handset (see page 2.4.)
- When the machine's memory is full

It is called *Real time transmission* mode. In this mode, the next page is not scanned in while the current page is being transmitted.

**Note:** In this mode, only one destination can be dialed.

## Sending a fax

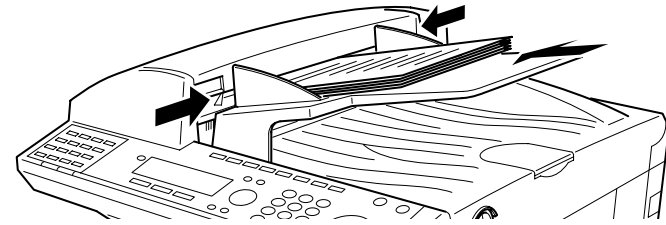

- 1** Insert the document **face up, top edge first**. Adjust the document guides — by sliding either of them to the left or right — to fit the page(s) you'll be faxing. Your fax machine's ADF (Automatic Document Feeder) will hold up to 80 pages with letter-sized paper.

When a document is in the feeder, the LCD shows the scanning width (see "A4, B4" in the Glossary beginning on page 5.16) and the amount of memory available:

```

Document Ready
Sep 27 2001 11:30am Mem:100%
  A4      Normal  Normal
    [ Mode ] [Contrast]
  
```

- 2** Adjust *resolution* and *contrast* if necessary.

- 3** Enter the fax number. Also, enter any access codes necessary, just as you would for a regular phone call. (Example: Enter 9 to "dial out" from an office telephone system, or 1 for long-distance.)

```

Press START
910123456789_
  A4      Normal  Normal
    [ Mode ] [Contrast]
  
```

- 4** Press **START**.

By pressing **START**, you've just given your machine a command. In turn, your machine gives this action a command number as it scans the fax document.

This command number appears on the first line of the LCD for a few seconds:

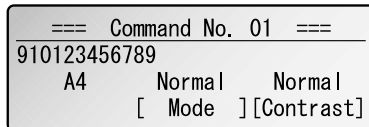

You'll need to know this command number if you later wish to cancel the transmission or to print a stored document (see pages 2.6–2.7).

- 5** Now, everything is up to the machines — yours and the one you're dialing.
- If the fax has been set for *Quick Memory transmit*, your machine scans the first page of your document into memory, then dials the other fax. When it makes contact, your machine transmits the stored document from memory while at the same time scanning the remaining pages of your document into memory. (In default setting, the *Quick Memory transmission* is *On*. If you want to turn off this feature, see page 4.2.)
  - If the fax has been set for the *normal memory transmit*, your fax scans the entire document into memory, then dials the other fax. When it makes contact, your machine transmits the entire stored document from memory.
  - If the fax is set for *Real time transmit (non-memory transmission)*, your machine simply dials the other fax. When it makes contact, your machine feeds the document through, scanning and transmitting it as it goes.

**Note:** The more “stuff” (called *black coverage*) your machine “sees” on a page, the slower the page feeds through as the fax scans it. And even if the page is relatively clean, sending it in grayscale mode or at certain resolutions makes your machine “see” more “stuff.” The same is true if you set the contrast to Dark.

**Important:** If you want to *cancel* a transmission while *scanning* the document, press the **STOP** key. If you want to *cancel* a transmission in progress, use the *Review Commands* feature. See “Reviewing or canceling commands,” page 2.6.

- 6** At the end of the operation, your fax machine beeps and displays:

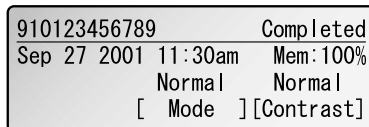

**Important:** Whenever you transmit a document, what actually appears on the top line of the display depends on information stored in the remote fax. The line may even be blank.

**Note:** If the call fails, see “Redialing,” page 2.5.

## Sending a fax using MONITOR/CALL key or a handset

You also can fax a document using either the monitor speaker or the optional handset to dial the call.

- 1** Insert the document to the ADF. If necessary, adjust *resolution* and *contrast*.
- 2** Obtain a dial tone, either by:
  - Pressing **MONITOR/CALL**
  - ... or ...
  - Lifting the optional handset.

In either case, the LCD shows:

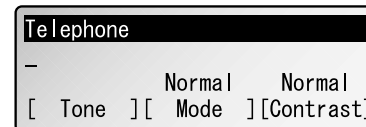

- 3** Enter the fax number by using the numeric keypad. Also, enter access codes with the number, just as for a regular phone call.

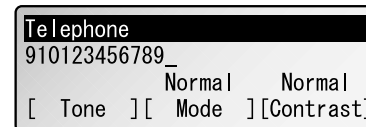

- 4** When you hear fax tones from the remote unit, press **START**.
 

**Note:** If a person answers the phone, use the optional handset to tell that person that you're trying to send a fax. When you hear fax tones, press **START**.
- 5** If you're using an optional handset, hang up after pressing **START**.
- 6** At the end of the operation, your fax machine will beep and display:

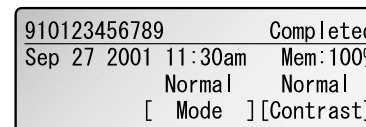

**Note:** If the call fails and you used **MONITOR/CALL** to dial, press **MONITOR/CALL** to hang up. Or if you've pressed **START** to begin the fax transmission, press **STOP** to end it.

Also see “Redialing manually,” next page, if the call fails.

## Redialing

### Automatically fax redialing

If your fax call fails, your machine automatically redials it. In this *Auto Redial mode*, your fax *automatically redials* the number up to two times at one minute intervals.

**Note:** You can change the redial time and interval settings. (See “Changing redial settings,” page 4.5.)

While in the *Auto Redial mode*, “AutoRedial” appears on the upper right of the LCD, and the machine can continue to receive faxes and can make as many as 99 fax transmissions.

Ready to Fax	AutoRedial
Sep 25 2001 11:00am	Mem: 100%
Normal	Normal
[ Mode ]	[ Contrast ]

**Note:** If you used either the **MONITOR/CALL** key or a handset to dial the call, you must redial manually (see below).

**Note:** If the last redial attempt fails, your machine may print (and/or display) error messages.

### Redialing manually

You can always redial calls manually. And you *must* redial manually if you used either the **MONITOR/CALL** key or an optional handset to dial the failed call.

*To redial a fax call manually without using the **MONITOR/CALL** key or an optional handset:*

- 1 Set the document and set the resolution and contrast.
- 2 Press **▲**(REDIAL). The LCD will show:

View Redial History
01:9-123-4567
02:9-234-5678
03:9-345-6789

- 3 Your machine can remember the last 10 dial numbers. Press **▲** or **▼** until the dial number you want to redial appears.
- 4 Press **START**.

*To redial a fax call manually with the **MONITOR/CALL** key or an optional handset:*

- 1 Make sure the document is in the ADF and that the resolution and contrast are set.
- 2 Press **MONITOR/CALL** or lift the optional handset to get a dial tone.
- 3 Press **▲**(REDIAL). The LCD will show:

View Redial History
01:9-123-4567
02:9-234-5678
03:9-345-6789

- 4 Your machine can remember the last 10 dial numbers. Press **▲** or **▼** until the dial number you want to redial appears.
- 5 When you hear fax tones from the remote unit, press **START**.
 

**Note:** If a person answers the phone, use the optional handset to tell that person you’re sending a fax. When you hear fax tones, press **START**.

*To redial a voice call manually using the optional handset:*

- 1 Lift the optional handset to get a dial tone.
- 2 Press **▲**(REDIAL). The LCD will show:

View Redial History
01:9-123-4567
02:9-234-5678
03:9-345-6789

- 3 Your machine can memory the latest 10 dial numbers. Press **▲** or **▼** until the dial number you want to redial appears.
- 4 Press **START**.
 

When the other person answers, use the optional handset to speak to that person.

## Reviewing or canceling commands

Your fax machine can store many “jobs” in its memory. It also keeps track of each command by assigning it a command number.

Delayed commands, redial attempts and current fax transmissions are all stored in your fax machine’s memory and given a command number.

Your machine can store up to 99 delayed commands. It identifies each by a two-digit *command number* from 01 to 99.

The *Review Commands* function gives you the power to check on each job (or command) in your machine’s memory. It also allows you to cancel a command of fax transaction if you decide not to send the document.

To see your machine’s stored commands or to cancel them:

- 1 Press **COMM. CANCEL/CONFIRM.**
  - The LCD shows the *first* command, indicated by its command number and the phone number it will dial.
  - If a command is in progress, that will be the first command the LCD shows:

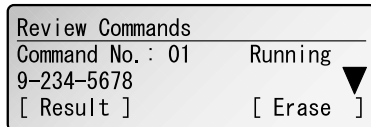

- If there are no stored commands in your machine — It beeps briefly and displays “No Command” on the LCD.

**Note:** If your machine is attempting to perform a command *now*, it appears on the display.

**Note:** You can see 100 most recent fax transactions and results of each transaction by pressing **[Result]**.

Here, you see *Command No. : 01*, and the number it’s set to dial. If the command is to send a *broadcast*, “Broadcast” appears instead of the phone number. (For more information of “Broadcasting,” see page 3.9.)

If the command is to send a *batch transmission*, the LCD shows its *batch box number* (such as “B01”) rather than the command number. (For more information of “Batch transmission,” see pages 3.12–3.14.)

If the command is for a *Call group dialing*, the group number (such as “G01”) appears instead of the phone number. (For more information of “Call group dialing,” see pages 3.6–3.7.)

**Note:** If your machine is attempting to perform a command *now*, it appears on the display.

- 2 Press **▲** or **▼** to scroll through currently stored commands.

- 3 If you want to cancel the command shown, press **[Erase]**. The LCD shows:

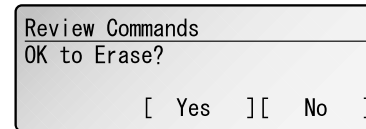

- 4 To go ahead with canceling the command, press **[Yes]**. Go back to step 2 to view other delayed commands.

To *keep* this command but to continue reviewing stored commands, press **[No]**. Go back to step 2.

To keep this command *and* stop reviewing commands, press **STOP** to return your machine to standby mode.

## Reviewing or canceling parts of a broadcast

You also can review or cancel certain numbers within a broadcast:

- 1 Press **COMM. CANCEL/CONFIRM.**
- 2 Press **▲** or **▼** to scroll through currently stored broadcast command.

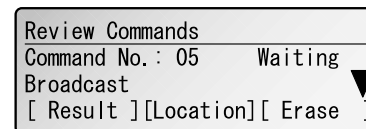

- 3 When the command you want to cancel shown, skip to step 6.

If you want to review *individual* numbers within this broadcast, go on to step 4 *without* pressing **[Erase]**.

- 4 To review *individual* numbers within this broadcast, press **[Location]** to see the first number. The LCD shows:

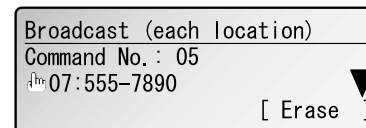

- 5 Press **▲** or **▼** until you find the number you want to cancel.

- 6 Press **[Erase]**, **[Yes]**. The next number will appear.

If you want to cancel this number, also, repeat this step.

If you want to cancel a different number, go back to step 5.

If you want to go back to reviewing or canceling other command, press **[No]**.

If you don't want to cancel any more numbers, press **STOP**. The machine returns to standby mode.

## Printing a delayed command list

Your machine can print a *command list* which tells you:

- The command's identification number
- The phone number, or "remote location"
- The start time (this appears in a *DD,HH:MM* format)
- A "note" telling if the command is a *polling* or *F-Code* operation (see pages 3.15–3.16 for more on *polling* and 3.27–3.37 for more on *F-Code communication*).

To print a delayed command list, press **MENU, 5, 1, 0, 4 ENTER**.

## Printing a stored document

Your fax machine can print out each document stored for delayed transmission. To print a stored document, you'll need to know the document's command number, which you can get by either reviewing the commands or printing a delayed command list (see above).

- 1 Press **MENU, 4, 3, 0, 5 ENTER**. The LCD shows:

```
05. Comm. Stored Document
Enter Command No. (01-99) : _
01:9-234-5678
```

- 2 Use the numeric keypad to enter the command's identification number, *01-99*. For example, we have entered the command number 05:

```
05. Comm. Stored Document
Enter Command No. (01-99) : _
05:9-123-4567
```

- 3 Press **ENTER**. Your fax machine will print a copy of the stored document.

## View the result of fax transaction

You can see 100 most recent fax transactions and result of each transactions with the following information.

- Assigned number, starting each day at 001
- Remote location called (The destination name)
- Resolution mode
- Starting date and time
- Duration, in minutes and seconds
- Number of pages you sent or received
- Result of the call — If preceded by an asterisk (\*), this signifies an ECM communication. If preceded by a pound (#), this signifies communication was via the highspeed V.34 modem.

**Note:** Your machine's LCD shortens the word *Transmission* to *Tx* and the *Reception* to *Rx*.

- 1 Press **COMM. CANCEL/CONFIRM.**

- 2 Press **[Result]**.

```
Journal No.001 Tx
9-234-5678 Normal
StartTime: 1/ 1 14:20 1' 17"
Result :#OK Page :1 ▼
```

- 3 Use the cursor key to scroll the results of each transaction.

**Note:** You can print a result of the fax transaction appears on the LCD by pressing **ENTER**.

- 4 If you wish to exit this mode, press **STOP**.

### Printing all result of daily fax transactions:

If you want to print the all result of today's fax transactions, press **MENU, 5, 1, 0, 3 ENTER**.

**Note:** You can set your machine to print all result of faxing automatically. See "Setting the Activity journal" on page 3.22 for more details.



# Receiving faxes

## Answering calls manually

In any reception mode, you can always answer calls manually *if you have an optional handset installed*. Just pick it up, as you would if using a normal phone.

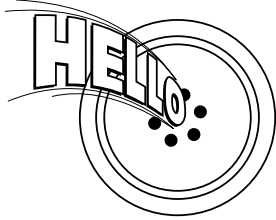

If you hear someone speaking to you, use your optional handset to speak back.

If you hear *fax tones* (“beep — beep — beep”), press **START** and hang up the optional handset. The fax machine will begin receiving a fax.

**Note:** Don’t try to answer a call by pressing **MONITOR/CALL**. The monitor function is for dialing only.

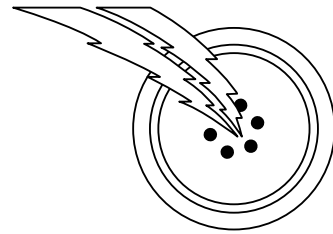

## Answering fax calls using another phone, not the fax machine

If you have one phone line ringing to several phones in your office and *you have an optional handset attached to your fax*, there’s no need to run to the fax machine to answer every call. If you happen to answer a fax call while you’re at another extension, put the handset down, but don’t hang up. Walk to the fax machine and pick up the optional handset. Then press **START**.

After you press **START**, hang up both the fax machine’s optional handset and the second telephone’s handset. Because remote fax machines will wait several seconds to hear reception tones from your unit, you have about 30 seconds to walk to your fax, pick up the handset, and press **START**.

## Reception modes

Your fax machine has five different reception modes — *Tel Ready*, *Fax Ready*, *Fax/Tel Ready*, *Tel/Fax Ready* and *Ans/Fax Ready*. We’ll explain each of these in this section.

### *Tel Ready mode*

- Use it if:**
- You want to use the same line for both fax and phone calls *and*
  - On that line, you’re using at least one other phone which is *not* connected to your fax machine *or*
  - You have an optional handset installed on your fax machine

**In this mode:** Your fax machine never answers calls automatically. You must answer each call as described in “Answering calls manually” (this page, left column).

### *Fax Ready mode*

**Use it if:** Your fax machine uses its own phone line and doesn’t share it with a phone or an answering machine.

**In this mode:** Your fax machine answers each call and attempts to receive a fax.

### *Fax/Tel Ready mode*

The Fax/Tel Ready mode is a combination of the Fax Ready and Tel Ready modes.

- Use it if:**
- An optional handset is installed on your fax machine *and*
  - You’re using the machine as both a fax machine and a telephone

**In this mode:** Your fax machine receives faxes silently *but also* alerts you when a regular voice call comes in. (Your fax machine also beeps once at the end of each reception.)  
If a voice call comes in, your fax machine detects it and sounds a special ring. If you hear it, answer using your optional handset.

**Note:** This Fax/Tel Ready mode won’t turn off ringers on other telephones in your house or office. Other phones won’t distinguish between fax and voice calls.

## Tel/Fax Ready mode

The Tel/Fax Ready mode is a combination of the Tel Ready and Fax Ready modes.

- Use it if:**
- An optional handset is installed on your fax machine
  - and
  - You're using the machine as both a telephone and a fax machine

**In this mode:** Your fax machine rings the number of times you've identified in the user settings (the default setting is two times). If you don't use the optional handset to answer the call, your fax machine answers the call. If a caller sends a fax, your machine begins receiving it. If a voice call comes in, your machine detects it and sounds a special ring, telling you to answer using the optional handset.

## Ans/Fax Ready mode

**Use it if:** You're using an answering machine that's connected directly to your fax machine.

**In this mode:** An answering machine connected to your fax machine answers each call. If a voice call comes in, the answering machine begins to record the incoming message. If your fax machine hears a fax tone, it begins receiving the fax message.

### Using an answering machine with your fax machine

To connect your answering machine to your fax machine:

- 1** Set the fax machine for Ans/Fax Ready, as described on right column.
- 2** Set your answering machine to answer calls after *no more than* two rings. (See the answering machine's instructions if necessary.)
- 3** Create a new outgoing message on your answering machine. Here's a suggested message:

*Hello! You've reached [your name or telephone number]. To leave a **voice** message, please wait for the beep. To send a **fax**, press **START** on your fax machine. Thanks for calling!*

**Important:** Your answering machine's outgoing message must be *no longer than* 10 seconds.

### Detection of "silent" fax machines

Some older fax machines don't send fax tones when transmitting, which can cause problems when using an answering machine with your fax.

But your fax machine can accommodate these "silent" machines *without* disrupting your answering machine operation.

## How to select the fax reception mode

- 1** Press **MENU**, **9**, and then press **ENTER** *four times*. The LCD shows your current fax reception mode:

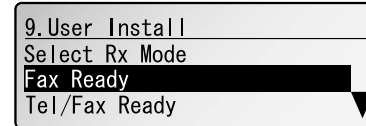

- 2** Using the cursor key, select your desired reception mode.
- 3** Press **ENTER** to save the setting.

## If the paper runs out while fax reception

When your machine runs out of paper, it beeps, the **ALARM** light glows and the LCD shows which source has run out of paper – the 1st cassette, 2nd cassette (optional) or the bypass tray.

In this example, the machine runs out of letter-sized paper in 1st cassette:

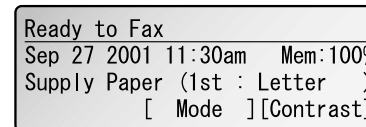

**Note:** If the letter, legal or half-letter sized paper has been set in the bypass tray, your machine uses it when running out of paper in the paper cassette(s) during fax reception. Your machine's bypass tray can hold up to 50 sheets of the paper.

Your fax machine cannot *print* fax messages without paper. But it can still receive documents into its memory, as described in the section below.

### Out-of-paper reception

If your machine runs out of paper, it stores up to 250 fax *receptions* in its memory. This is called *out-of-paper reception*. Once you refill the paper supply, the fax machine prints the stored messages automatically.

**Note:** The number of *pages* (not *receptions*) your fax machine can store for out-of-paper reception will vary. It depends on:

- Your machine's memory capacity
- Types of documents being sent to your machine
- Resolution of documents being sent to your machine

# Making copies

Your fax machine also doubles as a convenience copier.

To make copies with your fax machine:

- 1 Press **COPY** to change to Copy mode.

When the machine is in the Copy mode, the LCD shows:

```

Enter Number of Copies : 1
Ratio:100%             Mem:100%
      Fine             Normal
[ Mode ] [Contrast]
  
```

- 2 Place your original document in ADF **face up** just as you would send a fax.
- 3 As needed, set the following:
  - Adjust resolution mode and contrast
  - Enter the number of copies
- 4 Press **START** to start the copying.
 

**Note:** When you make multiple copies, your machine always sort copies.

**Note:** To stop the copying, press **STOP**.

## Changing the reduction ratio

Your fax machine is capable of reduction when copying. You can choose from 78% (Legal → Letter), 100% and Auto.

**Note:** If the “Auto” is set, the machine automatically reduce the original document size to fit on the paper size, which makes the margin as little as possible.

To change the reduction ratio:

- 1 Press **MENU, 2, 3, 0, 2, ENTER**.

```

02. Print Parameters
Exit
Reduction Ratio   :100 %
Reduction Margin  :24 mm ▼
  
```

- 2 To set the reduction rate for copying, select “**Reduction Ratio**” using the cursor key and then press **ENTER**. The LCD will show:

```

02. Print Parameters
Auto
100%
78%
  
```

- 3 Select from *Auto*, *100%* or *78%* for the copy reduction setting. Then press **ENTER**.
- 4 Press **STOP** to return to the standby mode.

## Using the bypass tray

When you need to use a size of paper not currently loaded in your machine’s paper cassette(s), or when you want to use a special type of paper (such as transparency film), use the bypass tray.

**Important:** Your machine automatically selects suitable paper according to the document size and reduction rate. So, if the suitable sized paper for your copying is in the paper cassette, the machine will use it even if you set the paper in the bypass tray.

**Note:** If the same sized paper is set in the both the paper cassette and bypass tray, turn the bypass tray priority mode (see page 4.7) to get the priority to use the paper which is set on the bypass tray than the paper in the cassette.

**Note:** If loading transparency (OHP) film into the bypass tray, be sure that the sheet is designed for laser printers and not for copiers. Also, be sure that the film does not have a paper backing and/or a leading strip. If it does, remove the paper backing and/or strip before inserting. Only film should go in, not film with any backing or strip.

- 1 Place your original document in ADF **face up** just as you would send a fax.
 

**Note:** Place the original document in the same orientation as the paper in the bypass tray.
- 2 Set the paper in the bypass tray.
 

See the table of “Acceptable paper size and cassette capacity” on page 1.7 and “Loading paper in bypass tray” on page 1.9 for more information.

- 3 If necessary, select desired resolution, contrast, reduction ratio.
- 4 Press **START** to begin the copying process.

---

## Memory overflow message

If you've stored too much information in your machine's memory, a "Memory Overflow" message may appear on the LCD.

*If the memory overflow occurred at the first page:*

```

Press STOP to Exit
Ratio 100%           Mem: 2%
Memory Overflow
  [ Mode ] [Contrast]
  
```

Press **STOP** to discharge the documents from the ADF.

*If the memory overflow occurred at the second page or later:*

```

Memory Overflow
# of Stored Pages: 28
Keep These Pages?
  [ Yes ] [ No ]
  
```

If this message appears, press **[Yes]** to tell your machine to print out the document stored in memory, or press **[No]** to erase all pages stored during the current operation (but not previous operations).

**Note:** If you don't operate your machine within 60 seconds, the machine will automatically print out the document stored in the memory during the current operation.

---

## If the paper runs out while copying

When your machine runs out of paper, it beeps, the **ALARM** light glows and the LCD shows which source has run out of paper – the 1st cassette, 2nd cassette (optional) or the bypass tray.

In this example, the machine runs out of the paper in the 1st cassette:

```

Ready to Fax
Sep 27 2001 11:30am  Mem:100%
Supply Paper (1st : Letter )
  [ Mode ] [Contrast]
  
```

If you want to cancel the current copying job, press **STOP**. Otherwise, supply the paper to displayed paper source to resume the copying.

# Using your fax machine as a phone

Your fax machine can also be used as a phone, if you have an optional handset installed. The following is a brief look at the machine's telephone features.

## Dialing a telephone number

- 1 Pick up the optional handset. You will hear a dial tone.
- 2 Dial the number by the using numeric keypad.  
— or —  
Press the one-touch key. (See “One-touch phone dialing,” on page 3.3.)  
— or —  
Press **SPEED DIAL/GROUP**, then press the three digit speed-dial number. (See “Phoning via speed-dial,” on page 3.5.)  
— or —  
Press **▼(TEL INDEX)**, then search the name you want to call using the cursor key. (See “Easy dial directory dialing,” page 3.8.)
- 3 When the other person answers, begin speaking.

## On-hook dialing

Because your machine has a monitor speaker, you can dial without picking up the optional handset. For hands-free dialing:

- 1 Press **MONITOR/CALL**. You'll hear a dial tone (unless you have set your speaker volume to *Off*; see page 1.7), and the LCD shows:

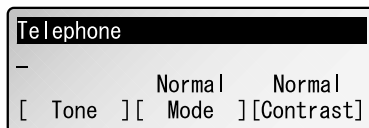

- 2 Dial the number you want. Use either the numeric keypad, a one-touch key, a speed-dial number or telephone index to dial.

**Important:** Your machine's monitor speaker is *not* a *speaker phone*. If a person answers the call, pick up the handset to speak.

**Note:** If the call fails, press **MONITOR/CALL** to hang up.

## Redial

- 1 Lift the optional handset to get a dial tone.
- 2 Press **▲(REDIAL)**. The LCD will show:



- 3 Your machine can remember the latest 10 dial numbers. Press **▲** or **▼** until the dial number you want to redial appears.
- 4 Press **START**.  
When the other person answers, use the optional handset to speak.

## Call request

You can send or receive a fax message *and* have a regular phone conversation *on the same call*.

For more information on how to use this function, see page 3.26.

## Changing the dialing type

If, with your machine set for “pulse” dialing, you must enter tones (“DTMF”) during a call, press **[Tone]** (the “-!” symbol will be shown on the LCD). Your machine now will “tone” dial all subsequent numbers.

**Note:** Using this key enables tone transmission from the numeric keypad after the call is connected. When you hang up the call, your machine will return to “pulse” dialing for the next call.

## Dialing in the event of a power failure

If your fax is equipped with an optional handset, you can use that handset to manually answer calls in the event of a power failure. But your fax machine cannot send or receive a fax during a power failure.

## Attaching an optional handset

You may purchase an optional handset for your fax machine. Here is how to attach the handset.

- 1 Using a Phillips-head screwdriver, attach the handset cradle to the left side of your machine, using the screws included with the cradle.

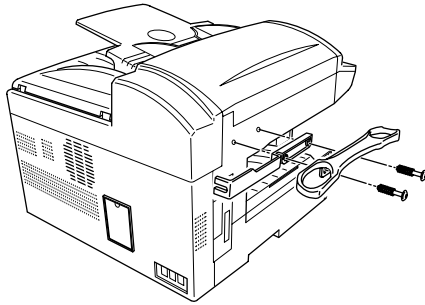

- 2 Plug one end of the handset cord (it's curled) into the **PHONE1** jack on the rear side of your machine.

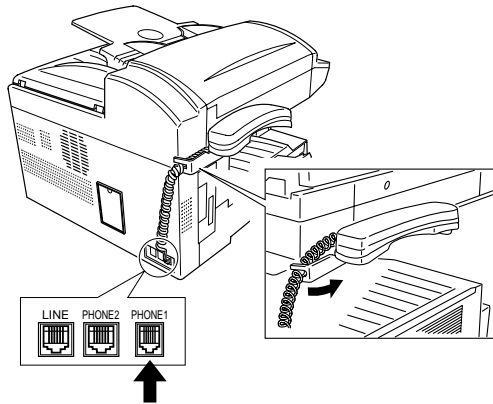

- 3 Plug the other end of the handset cord into the jack on the handset. If connected to a phone line, your fax machine is now “off-hook.”

**Note:** The handset has a small “flash” button which you can press while holding the handset, putting the fax machine back “on-hook” until you can hang up the handset properly in step 4.

- 4 Place the telephone handset onto the handset cradle. The cradle will press the handset’s “flash” button, hanging up the handset.

## Attaching a second phone

Want to attach a second phone (even a cordless model!) to your fax machine, so they can share the same phone jack? No problem.

Before we go further, let’s explain the idea. You’re plugging the second phone’s phone line into your machine’s **PHONE2** jack, not the wall phone jack. In such a setup, only your machine connects to the wall. The second phone receives phone signals through your machine.

Now, let’s proceed...

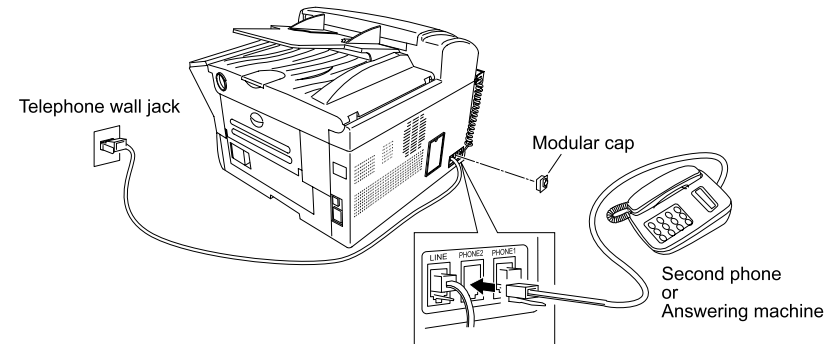

- 1 If your second phone is already plugged into a wall phone jack, disconnect it from that jack. Hold onto the phone plug; you’ll need it in step 2.

**Note:** Of course, if your second phone is a model which requires AC power, as is true for the base of a cordless phone, don’t unplug it from its AC power jack!

- 2 Using the plug mentioned in step 1, plug the phone cable from your second phone into the **PHONE2** jack on the left side of your fax machine.

# Advanced Features

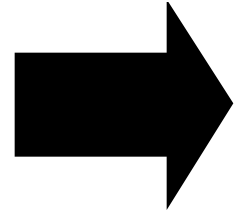

*This chapter describes  
convenient features of your  
machine.*

Autodialer .....	3.1
Broadcasting .....	3.9
Delayed transmission .....	3.11
Batch transmission .....	3.12
Polling .....	3.15
Soft keys .....	3.17
Special features .....	3.18
Security features .....	3.46

# Autodialer

Your fax machine's *autodialer* stores your most frequently called phone and fax numbers for instant recall so you don't have to remember them. It's something like an electronic phone book.

## Autodialer basics

### How do you autodial?

There are two kinds of autodialer numbers. The difference between the two is how you dial them:

Type	How to dial	Amount stored
<i>One-touch</i>	Press one of the keys, marked <b>01–56</b> on the left side of the control panel	56
<i>Speed-dial</i>	Press <b>SPEED DIAL/GROUP</b> followed by a three-digit identifier, from <i>001</i> to <i>244</i>	244
<b>Total amount of numbers stored</b>		<b>300</b>

### Call groups

As you set up your autodialer, you may also want to set up *call groups*. These are sets of phone numbers that make it easy to send the same fax to many different locations. For example, one call group may include all of your clients in one city, another group may include all of your employees and another may include all your vendors.

Your fax machine can store as many as 300 numbers in up to 32 call groups.

See also “Call group dialing,” page 3.6.

### Location IDs and the EasyDial directory

When you store numbers in your autodialer, you can give these numbers descriptive names, such as “Chicago office” or “Billing department”. Your machine calls this name a *Location ID*.

Your machine's autodialer sorts these location IDs alphabetically. Using your *EasyDial directory*, you can look up these numbers by their descriptive names, just as if you were using a phone book.

We'll explain how to store the numbers and location IDs in the next few pages. The EasyDial directory is discussed in detail on page 3.8.

## Special Dialing Characters

Your fax machine allows you to enter special dialing characters when programming the autodialer. These characters include hyphens, which make phone numbers easier to read, and special characters needed for international calls.

The chart below briefly describes each of these characters. It also tells you what keys to press on your fax machine to store those characters in your autodialer:

Char.	What it does	Keystroke(s)
- /	Enters a pause. Each pause lasts two seconds (or whatever length you set; see page 4.5). Each pause uses <i>two</i> of the characters you can store in one phone number.	PAUSE/DIAL OPT. ( <i>once</i> ) [after you enter at least one other character]
-	Makes long numbers easier to read. Doesn't change fax machine operation.	PAUSE/DIAL OPT. ( <i>twice</i> )
/	( <i>Has no effect in the United States.</i> )	PAUSE/DIAL OPT. ( <i>3 times</i> )
!	Tells your fax machine to pause until it “hears” a dial tone.	PAUSE/DIAL OPT. ( <i>4 times</i> )
-!	If your fax machine is on a pulse ( <i>not</i> tone-dialing) line, switches from pulse-dialing to tone (“DTMF”)-dialing. Use after the actual phone number but before any characters (such as a long-distance carrier's access code) which must be in DTMF tone. <i>Do not</i> use on a tone line.	PAUSE/DIAL OPT. ( <i>5 times</i> )



## Using one-touch keys

Your fax machine stores up to 56 one-touch numbers using the keys marked **01–56**.

### Entering or changing a one-touch number

- 1 Press **MENU, 1, 1, 0, 1, ENTER**. The LCD shows the empty one-touch number:

01. Enter One-Touch  
Select One-Touch (01-56)  
01: No Number Stored

**Note:** If a one-touch number other than **01** appears on the LCD, it means that you have already entered a number for **01**.

- 2 Using the cursor key, select the one-touch key in which you want to store a number or change a previously stored number.

**Note:** You can select the one-touch key by pressing that key on the control panel.

- 3 Press **ENTER**. The LCD shows:

01:  
Enter Fax Number  
-

- 4 Use the numeric keypad to enter the number *exactly* as your machine should dial it, including whatever access codes your phone system requires. (You may want to review “Special dialing characters,” page 3.1.) The number can be up to 40 characters in length:

Your LCD can show only 30 characters at a time. To view characters beyond those 30, press **◀** to scroll to the left or **▶** to scroll to the right.

- 5 When the number is as you want it, press **ENTER** to store it. The LCD now shows:

01: 123-4567  
Exit  
Location:

- 6 Select **“Location”** and press **ENTER**. The LCD shows:

01: 123-4567  
Location Lower Case  
-

**Note:** If a Location ID is already registered in this one-touch key, it is shown on the LCD. If you wish to change the location ID, press **CANCEL** to erase it and then enter another location ID.

- 7 Enter the Location ID. (Regarding how to enter the character, see “Entering character” on page 1.12.) A number’s Location ID may be up to 24 characters in length.

- 8 Press **ENTER** to save the setting.

- 9 Select **“Exit”** and press **ENTER**.

The LCD will display the next empty one-touch number.

If you *do* want to enter *another* one-touch number, go back to step 2.

If you *do not* want to enter any more one-touch numbers, press **STOP** to finish.

Use the autodialer labels in your fax’s packaging to write down the stored numbers for easy reference.

### Erasing a one-touch number

- 1 Press **MENU, 1, 1, 0, 2, ENTER**. The LCD shows the one-touch number you have already entered:

02. Erase One-Touch  
Select One-Touch (01-56)  
01: 123-4567

**Note:** If the one-touch number that appears is other than **01**, it means that **01** is empty.

- 2 Select the one-touch key you want to erase.

**Note:** You can select the one-touch key by pressing that key on the control panel or using the cursor key.

**3** Press **ENTER**. The LCD shows:

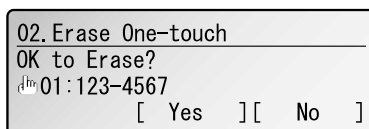

**Important:** If you want to quit without erasing the one-touch number you've selected, press **[No]**. The fax will return to step 2.

**4** Press **[Yes]** to erase the number.

To erase another one-touch number, repeat steps 2–4. Otherwise, press **STOP** to return to standby mode.

## Printing a list of one-touch numbers

Forgot which number is stored in which one-touch key? Just print a list of your one-touch numbers. The list includes each key's number, the Location ID (if any) and fax/telephone number you've stored in the key.

To print a list of one-touch numbers, press **MENU, 5, 1, 0, 5, ENTER**.

## One-touch fax dialing

To dial a *fax* call using a one-touch number:

- 1** Place the the document in the ADF.
- 2** Adjust resolution and contrast if necessary.
- 3** Press the one-touch key in which you've stored the number.

What happens next depends on whether you specified memory transmission or real time transmission:

*If you specified Quick Memory transmission:*

- Your fax machine scans the first page of your document into memory, then dials the other fax machine.
- While dialing, your machine scans the other documents into memory.
- The LCD shows the Location ID and the document's width and resolution settings:  
**Note:** If the one-touch key doesn't have a Location ID, the number appears.
- When the other machine answers, your fax transmits the scanned document directly from memory. (To review Quick memory transmission, see page 2.2.)

*If you specified normal memory transmission:*

- Your fax machine scans your entire document into memory first, then dials the other fax machine.
- The LCD shows the Location ID and the document's width and resolution settings:  
**Note:** If the entry doesn't have a Location ID, the number appears.
- When the other machine answers, your fax transmits the document directly from memory. (To review Memory transmission, see page 2.2.)

*If you specified real time transmission:*

- Your fax machine dials the other fax machine.
- The LCD shows the Location ID and the document's width and resolution settings:  
**Note:** If the entry doesn't have a Location ID, the number appears.
- When the other machine answers, your fax feeds the document through its scanner, transmitting as it goes. (To review Real time transmission, see page 2.3.)

## One-touch phone dialing

To dial a *phone* call using a one-touch number, you *must* have an optional handset attached to your machine. (Contact your authorized Muratec dealer to order an optional handset.)

To make the call:

- 1** Obtain a dial tone by doing one of the following:
  - Lift the optional handset
  - Press **MONITOR/CALL** to use the monitor speaker
- 2** Press the one-touch key in which you've stored the number. As the machine dials, it shows the number on the LCD:

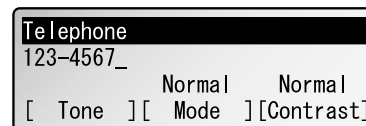

**Note:** Remember that your fax machine's monitor speaker is **not** a *speakerphone*. If you dialed by using the monitor speaker, pick up the handset to speak to the person that answers.

**Note:** If the call fails, and you used **MONITOR/CALL** to dial, press **MONITOR/CALL** to hang up.

## Using speed-dial numbers

Your fax machine will store up to 244 speed-dial numbers, designated by three-digit identifier codes from 001 through 244.

### Entering or changing a speed-dial number

- 1 Press **MENU, 1, 2, 0, 1, ENTER**. The LCD shows:

```
01. Enter Speed-Dial
Select Speed-Dial (001-244) : _
001: No Number Stored
```

**Note:** If a speed-dial number other than **001** appears on the LCD, it means you have already entered a number for **001**.

- 2 Using the cursor key, select the speed-dial number in which you want to store a number or change a previously stored number.

**Note:** You can select the speed-dial number by directly entering that three-digit identifier code. When entering the identifier code for speed-dial numbers less than 100, you must enter leading zeroes to make three digits. For example, *001-099*.

- 3 Press **ENTER**. The LCD shows:

```
001:
Enter Fax Number
-
```

- 4 Use the numeric keypad to enter the number *exactly* as your machine should dial it, including whatever access codes your phone system requires. (You may want to review “Special dialing characters,” page 3.1.) The number can be up to 40 characters in length:

Your LCD can show only 30 characters at a time. To view characters beyond those 30, press **◀** to scroll to the left or **▶** to scroll to the right.

- 5 When the number is as you want it, press **ENTER** to store it. The LCD now shows:

```
001: 123-4567
Exit
Location:
```

- 6 Select **“Location”** and press **ENTER**. The LCD shows:

```
001: 234-5678
Location          Lower Case
-
```

**Note:** If a Location ID is already registered in this one-touch key, it is shown on the LCD. If you wish to change the location ID, press **CANCEL** to erase it and then enter another location ID.

- 7 Enter the Location ID. (Regarding how to enter the character, see “Entering character” on page 1.12.) A number’s Location ID may be up to 24 characters in length.

- 8 Press **ENTER** to save the setting.

- 9 Select **“Exit”** and press **ENTER**.

The LCD will display the next empty speed-dial number.

If you *do* want to enter *another* speed-dial number, go back to step 2.

If you *do not* want to enter any more speed-dial numbers, press **STOP** to finish.

### Erasing a speed-dial number

- 1 Press **MENU, 1, 2, 0, 2, ENTER**. The LCD shows:

```
02. Erase Speed-Dial
Select Speed-Dial (001-244) : _
001: 234-5678
```

- 2 Select the speed-dial in which you want to erase.

**Note:** You can select the speed-dial number by directly entering that three-digit identifier code. When entering the identifier code for speed-dial numbers less than 100, you must enter leading zeroes to make three digits. For example, *001-099*.

- 3 Press **ENTER**. The LCD shows:

```
02. Erase Speed-Dial
OK to Erase?
001: 234-5678
[ Yes ] [ No ]
```

**Important:** If you want to quit without erasing the speed-dial number you’ve selected, press **[No]**. The fax will return to step 2.

- 4 Press **[Yes]** to erase the number.

To erase another one-touch number, repeat steps 2–4. Or press **STOP** to return to standby mode.

### Printing a list of speed-dial numbers

You can easily print a list of your speed-dial numbers. The list includes each number's three-digit identifier, the Location ID (if any) and fax/telephone number you've stored for that speed-dial number.

To print a list of speed-dial numbers, press **MENU, 5, 1, 0, 6, ENTER**.

### Fax dialing via speed-dial

To dial a *fax* call using a speed-dial number:

- 1 Place the document in the ADF.
- 2 Adjust resolution and contrast if necessary.
- 3 Press **SPEED DIAL/GROUP** once. The LCD shows:

```

Enter Speed-Dial No.
S_
           Fine   Normal
           [ Mode ] [Contrast]
  
```

- 4 Use the numeric keypad to enter the three-digit identifier (such as *018*, in this example) for the speed-dial number you want to dial. The LCD shows the Location ID (or fax number) you stored:

```

Enter Speed-Dial No.
S018:Plano Office
           Fine   Normal
           [ Mode ] [Contrast]
  
```

- 5 Press **START**.

What happens next depends on whether you specified memory transmission or real time transmission:

*If you specified quick memory transmission:*

- Your fax machine scans the first page of your document into memory, then dials the other fax machine.
- While dialing, your machine scans the other documents into memory.
- The LCD shows the Location ID and the document's width and resolution settings:  
**Note:** If the entry doesn't have a Location ID, the number appears.
- When the other machine answers, your fax transmits the scanned document directly from memory. (To review Quick memory transmission, see page 2.2.)

*If you specified normal memory transmission:*

- Your fax machine scans your entire document into memory, then dials the other fax machine.
- The LCD shows the Location ID and the document's width and resolution settings:  
**Note:** If the speed-dial entry doesn't have a Location ID, the number appears.
- When the other machine answers, your fax will transmit the document directly from memory. (To review Memory transmission, see page 2.2.)

*If you specified real time transmission:*

- Your fax machine dials the other fax machine.
- The LCD shows the Location ID and the document's width and resolution settings:  
**Note:** If the speed-dial number doesn't have a Location ID, the number appears.
- When the other machine answers, your fax feeds the document through its scanner, transmitting as it goes. (To review the Real time transmission, see page 2.3)

### Phoning via speed-dial

To dial a *phone* call using a speed-dial number, you *must* have an optional handset attached to your machine. To make the call:

- 1 Obtain a dial tone by doing one of the following:
  - Lift the handset
  - Press **MONITOR/CALL** to use the monitor speaker
- 2 Press **SPEED DIAL/GROUP** once. The LCD shows:

```

Enter Speed-Dial No.
S_
           Normal  Normal
           [ Tone ] [ Mode ] [Contrast]
  
```

- Use the numeric keypad to enter the three-digit identifier for the speed-dial number you want to dial. As the machine dials, it shows the number on the LCD:

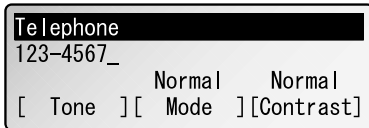

- Note:** Remember that your fax machine's monitor speaker is **not** a *speakerphone*. If you dialed using the monitor speaker, pick up the handset to speak to the person that answers!
- Note:** If the call fails, and you used **MONITOR/CALL** to dial, press **MONITOR/CALL** to hang up.

## Call group dialing

If you frequently send the same fax message to more than one location, store the one-touch key(s) or speed-dial number(s) into a group.

After you store, you can send the same fax to many different locations by pressing **SPEED DIAL/GROUP**.

### Entering or changing a call group

- Press **MENU, 1, 3, 0, 1, ENTER**. The LCD shows the empty group number:

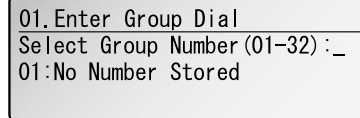

- Note:** If a group number other than **01** appears on the LCD, it means that you have already entered numbers for **01**.
- Using the cursor key, select the group number in which you want to store a number or change a previously stored number.
- Note:** You can select the group number by directly entering that two-digit identifier code. When entering the identifier code for group numbers less than 10, you must enter leading zero to make two digits. For example, *01-09*.

- Press **ENTER**. The LCD shows:

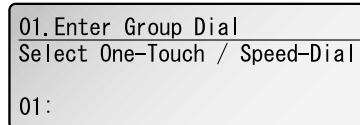

- Enter all the one-touch number(s) or the speed-dial number(s) you want to store into the group number by pressing the one-touch key or **SPEED DIAL/GROUP** and the numeric keypad. A comma will be automatically inserted between each number.

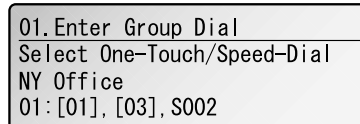

Your LCD can show only 30 characters at a time. To view characters beyond those 30, press ◀ to scroll to the left or ▶ to scroll to the right.

- When all numbers are entered, press **ENTER** to store it.

- 6** The LCD will display the next empty group number. If you *do* want to enter numbers for *another* group number, go back to step 2. If you *do not* want to enter any more numbers, press **STOP** to return to standby mode.

## Erasing a call group

- 1** Press **MENU, 1, 3, 0, 2, ENTER**. The LCD shows:

```
02. Erase Group Dial
Select Group Number (01-32) : _
01: [01], [03], S002
```

- 2** Using the cursor key, select the group number you want to erase.

**Note:** You can select the group number by directly entering that two-digit identifier code. When entering the identifier code for group numbers less than 10, you must enter leading zero to make two digits. For example, *01-09*.

- 3** Press **ENTER**. The LCD shows:

```
02. Erase Group Dial
OK to Erase?
01: [01], [03], S002
      [ Yes ] [ No ]
```

**Important:** If you want to quit without erasing the group number you've selected, press **[No]**. The machine will return to step 2.

- 4** Press **[Yes]** to erase the number.

To erase another group number, repeat steps 2–4. Otherwise, press **STOP** to return to standby mode.

## Send a fax via call group

**Note:** The call group dialing can be used only with memory transmission.

- 1** Place the document in the ADF. Adjust resolution and contrast if necessary.
- 2** Press **SPEED DIAL/GROUP** twice.

```
Enter Group Number
G_
      Fine   Normal
      [ Mode ] [ Contrast]
```

- 3** Use the numeric keypad to enter the group number you want to send a fax.

**Note:** If you want to send a fax to several groups at a time, press **BROADCAST** then repeat steps 2–3. Also, you can include the one-touch location, speed-dial location and up to 30 manually dialed number. (See “Broadcasting,” page 3.9.)

- 4** Press **START**.

## Printing a call group directory

Your machine can also print a *call group directory*. This lists all your stored autodialer numbers by Location ID and lists the groups to which these numbers belong.

The directory divides the call groups into four banks, *01–09* (the list shows *00*), *10–19* (the list shows *10*), *20–29* (the list shows *20*) and *30–32* (the list shows *30*). If you specify call group *0* (which puts the number in all call groups), the directory shows all numbers (see below).

For example, the directory might show:

No.	Location	00	10	20	30
[01]	Carson Co	4	0 4		
[02]	Tex. Ofc.	1			
[03]	e.e.gummi			0	2
S001	And Sew I	2 4			
S002	KC Enterp	7	0	1	
S003	Katz Cat	1 2 3 4 5 6 7 8 9	0 1 2 3 4 5 6 7 8 9	0 1 2 3 4 5 6 7 8 9	0 1 2

In this list, one-touch number 01 (*01*) is in groups 4, 10 and 14; one-touch number 02 (*02*) is in group 1; one-touch number 03 (*03*) is in groups 20 and 32; speed-dial number 001 (*S001*) is in call groups 2 and 4; speed-dial number 002 (*S002*) is in groups 7, 10 and 21; and speed-dial number 003 (*S003*) is in all groups, 1 to 32.

To print a call group directory, press **MENU, 5, 1, 0, 7, ENTER**.

## EasyDial directory dialing

*EasyDial directory dialing* makes your autodialer even more like an electronic phone book. EasyDial sorts and displays numbers alphabetically according to their Location IDs, so you can find them and dial them easily.

To dial using EasyDial:

- 1 *For a regular phone call:* Pick up the optional handset.

**Note:** To make a regular phone call from your machine, you must have an optional handset attached.

*For a fax call:* Place the document in ADF. And adjust resolution and contrast if necessary.

- 2 Press ▼(TEL INDEX). The LCD shows the *first* listing in your fax machine's EasyDial directory:



The EasyDial directory sorts entries alphabetically in the following order: (1) by alphabet, (2) by number and (3) by symbol.

If the listing that appears is the one you want to dial, skip to step 4. Otherwise, proceed to next step.

- 3 Scroll through the listings to find the one you want. You do this by pressing the following cursor key:
  - ▲ or ▼ to select the character set — alphabet, number or symbol — for the *first* character of the Location ID.
  - ◀ or ▶ to check different listings within that character set.

**Note:** The scrolling is “open-ended.” For example, when you run out of listings beginning with alphabet “A”, pressing ◀ or ▶ automatically moves you into listings beginning with other characters.
- 4 When the LCD displays the name you want to dial, press **START**.
  - If you've set the document in the ADF, your machine will start the fax transmission.
  - If you make a regular phone call, speak after a person answers.

## If an EasyDial call fails

If an EasyDial call fails, what happens next depends upon the kind of call it was.

*If it was a fax call ...*

... Your fax machine automatically redials the number according to the redial interval you've set. It keeps trying until either of the following occurs:

- It successfully reaches the other number
- It has attempted the number of redials programmed and has still not connected (see “Changing redial settings,” page 4.5).

*If it was a regular phone call ...*

... You'll have to redial manually:

- 1 Lift the optional handset.
- 2 Press ▲(REDIAL). The LCD will show:

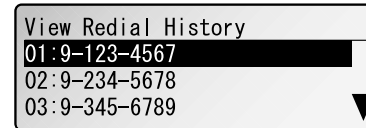

- 3 Your machine can remember the latest 10 dial numbers. Press ▲ or ▼ until the dial number you want to redial appears.
- 4 Press **START**.

# Broadcasting

The fastest way to fax *one* document to *many* recipients is to *broadcast* it.

In an ordinary broadcast, you send the fax as you normally would, except you just add more fax numbers. You can enter up to 330 numbers:

- 30 manually-dialed numbers **AND**
- 300 autodialer numbers **OR** 1 call group with all 300 autodialer numbers

**You can broadcast using any function that requires a fax number to be entered.** That means you can send a *delayed* broadcast, program a *polling* broadcast and even broadcast to “hub” units for F-Code *relay broadcast initiation*. All of these are explained in this chapter.

To send a broadcast fax:

- 1 Insert the document and make any necessary adjustments as you would for a regular fax transmission.
- 2 Press **BROADCAST**.
- 3 Enter the *first* fax number, as usual. Use either a one-touch number, a speed-dial number, a call group or a regular number dialed from the numeric keypad.
- 4 To add more fax numbers, press **BROADCAST**. Then enter the number as described in step 3. You can send to up to 330 numbers for a broadcast.

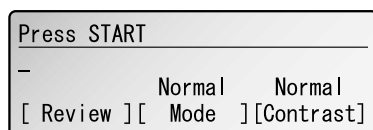

**Note:** If you enter characters by mistake, press **CANCEL** to erase them.

**Note:** If you want to review the numbers you entered, press **[Review]**.

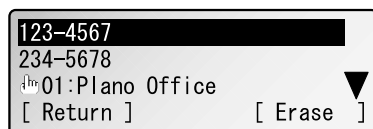

If you want to erase any number, move the cursor on it and press **[Erase]**.

When you are finished, press **[Return]** to return to the previous display.

- 5 Press **START**. Your fax machine scans the document into memory and then sends it to each number or call group you've entered.

## Delayed broadcasting

What if you want the broadcast to take place later? That's the purpose of setting up a *delayed broadcast*.

**Note:** Delayed commands are discussed on pages 2.6 and 2.7. And you may want to read “Delayed transmission” on page 3.11 before proceeding.

- 1 Follow steps 1–4 of “Broadcasting basics” (left column).
- 2 Press **COMM. OPTIONS**. The LCD shows:

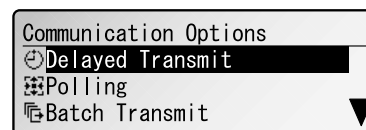

- 3 Select “**Delayed Transmit**” and press **ENTER**. The LCD shows:

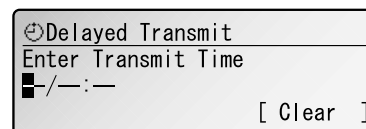

- 4 Use the numeric keypad to enter the day of the month and the time (in 24-hour format) when you want the fax to send the delayed transmission.

**Note:** Press ◀ to move the cursor left, or ▶ to move it right.

Here, we've set the transmission to occur on the 27th at 2:30 PM:

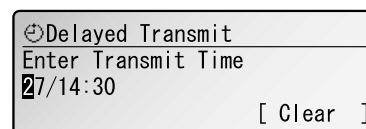

**Note:** If you *do not* want to delay the transmission, press **[Clear]**.



## Advanced features

- 5 Press **ENTER** to save the setting.
- 6 Press **START**. Your machine will scan your document into the memory and return to standby mode, while showing this on the LCD:

Ready to Fax	Reserved
Sep 25 2001 11:00am	Mem: 99%
Normal	Normal
[ Mode ]	[ Contrast ]

This means your fax machine is “reserved” for the delayed broadcast you just programmed, but it can still be used to send and receive faxes or to make copies if your broadcast document is stored in memory.

---

## Reviewing or canceling parts of a broadcast

If you need to review or cancel a broadcast you set, see “Reviewing or canceling parts of a broadcast,” page 2.6.

# Delayed transmission

Take advantage of lower evening and weekend long-distance rates with *delayed transmission*. Your fax machine can store up to 99 delayed commands, each of which you can program up to 31 days in advance.

**Important:** If you program all 99 delayed transmission commands, no further *memory* transmission is possible until one or more of the commands is completed. (To review Memory transmission, see page 2.2.) However, if all 99 delayed commands are programmed, you can always transmit with the Real time transmission from ADF (see page 2.3).

## Setting up a delayed transmission

**Important:** Your machine only remembers the *day* of the month that it's supposed to send a delayed transmission. It does not remember the month itself. So if you want to send a transmission at 5:05 PM on **June 26**, don't program the transmission sooner than 5:06 PM on **May 26**.

To set up a delayed transmission:

**1** Insert the document and make any necessary adjustments.

**2** Press **COMM. OPTIONS**. The LCD shows:

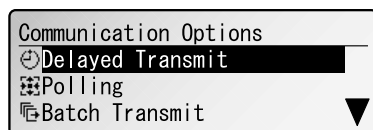

**3** Select **"Delayed Transmit"** and press **ENTER**. The LCD shows:

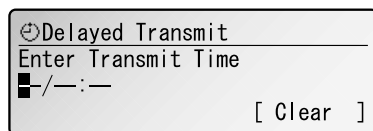

**4** Use the numeric keypad to enter the day of the month and the time (in 24-hour format) when you want the fax to send the delayed transmission.

**Note:** Press ◀ to move the cursor left, or ▶ to move it right.

Here, we've set the transmission to occur on the 27th at 2:30 PM:

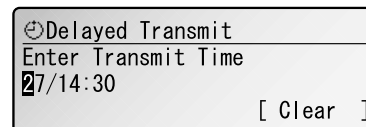

**Note:** If you *do not* want to delay the transmission, press **[Clear]**.

**5** When the date and time are entered, press **ENTER** to save the delayed transmission. The LCD shows:

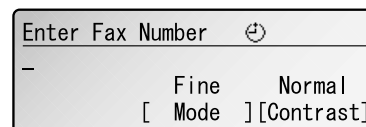

**6** Enter the fax number for the delayed transmission document. You can either press a one-touch key, enter a speed-dial number or use the numeric keypad to enter the fax number.

**7** Press **START**. Your machine returns to standby mode, while showing this on the LCD:

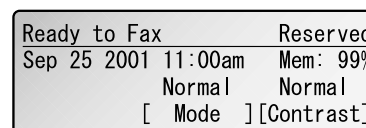

This means your fax machine is "reserved" for the delayed transmission you just programmed.

- If you set the machine for *memory transmission*, it will scan the document into memory, after which you can use the machine normally.
- If you set the machine for *non-memory transmission (real time transmission)*, the machine can *receive* faxes but can't *transmit* until your delayed command has been performed.

**Important:** If you specified the delayed non-memory transmission (real time transmission), do not remove the document in ADF. If the document is removed from ADF before a delayed command completes, it cancels the delayed real time transmission.

# Batch transmission

Batch transmission allows you to store multiple documents in an electronic “basket” throughout the day and then fax that entire basket to *one* location.

To do this, just tell the machine when and where the transmission should go. When that date and time arrives, your machine will transmit each document in the batch box to the remote fax machine. You can store up to 40 documents (each document can include one page or many pages) into your machine’s five electronic *batch boxes*.

## Creating or modifying a batch box

Before sending a batch transmission, you have to create batch boxes in your fax machine. The steps below also let you modify existing batch boxes.

To create or modify a batch box:

- 1 Press **MENU, 3, 6, 0, 1, ENTER**. The LCD shows:

```
01. Set Batch Box
Enter Box Number (1-5) : _
1. No Number Stored
```

- 2 Use the numeric keypad to enter the number (1–5) of the batch box you want to create or modify.

- 3 Press **ENTER**. The LCD now shows:

```
01. Set Batch Box
1: Enter Fax Number
-
```

- 4 Use the numeric keypad to enter the fax number *exactly* as your machine should dial it, including whatever access codes your phone system requires. (You may want to review “Special dialing characters,” page 3.1.) The number can be up to 40 characters in length.

**Note:** Your display can show only 30 characters at a time. To view characters beyond those 30, press ◀ to scroll to the left or ▶ to scroll to the right.

- 5 When the number appears as you want it, press **ENTER**. The LCD now shows:

```
01. Set Batch Box
1: Enter Transmit Time
- / - : -
```

- 6 Instruct your fax to send from this batch box in *one* of the following ways:

- Option 1:** *Once* at a certain time on a certain day of the month (For example: “Do this at 5:05 PM on the 30th.”) — Use the numeric keypad to enter the date and time (24-hour format) the machine should send the documents from the batch box:

```
01. Set Batch Box
1: Enter Transmit Time
30/17:05
```

- Option 2:** At a certain time *each day* you press the key (For example: “Do this at 5:05 PM today.”) — Use the numeric keypad to enter **0, 0** (00), and then the time when the fax should send the documents from the batch box:

```
01. Set Batch Box
1: Enter Transmit Time
00/17:05
```

**Note:** To change a digit in the date or the time, press ◀ to move the cursor left or ▶ to move it right. Then enter the correct number.

- 7 When the date and time are set, press **ENTER**. The LCD now shows:

```
01. Set Batch Box
1: Location Lower Case
-
```

The machine now asks you to name this batch box.

If you *do not* want to enter or change this batch box’s name, skip to step 9.

- 8 Enter the name by using the numeric keypad. (If necessary, review “Entering characters”, page 1.12) A batch box’s name may be up to 24 characters in length.
- 9 Press **ENTER** to save the batch box information.

To create or modify another batch box, repeat steps 2–9.  
To finish, press **STOP**.

## Printing a list of batch boxes

You can easily print a list of your batch boxes. The list includes each box’s identifier number, the Location ID, fax number and date/time the transmission should start. To print the list, press **MENU, 5, 1, 1, 4, ENTER**.

## Storing a document for batch transmission

Your fax machine can store up to 40 *documents* (each document can include one page or many pages) in each batch box until the date and time you designate the batch transmission to take place. Once the batch documents are transmitted, they are automatically erased from the machine’s memory.

**Note:** For this operation to work, two things must be true:

- The batch box must exist on your fax machine.
- You must know the batch box’s one-digit number (1–5).

To store a document in a batch box for batch transmission:

- 1 Insert the document and make any necessary adjustments.
- 2 Press **COMM. OPTIONS**. The LCD shows:

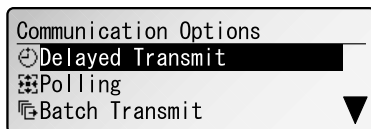

- 3 Select “**Batch Transmit**” and press **ENTER**. The LCD shows the batch box name and transmission time:

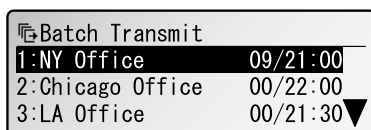

- 4 Select the batch box you want to use.
- 5 Press **ENTER**. The LCD shows:

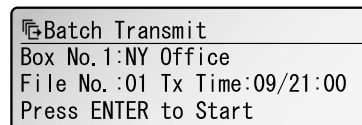

Your machine gives each document in a batch box a *file number*. You will need to know this file number should you later wish to erase or print the stored document. Each batch box holds up to 40 files (1–40).

- 6 Press **ENTER**. The machine displays “Reserved” on the top line of the LCD. This means the document is stored in memory.

## Printing a list of stored batch documents

You can print a list of the documents stored in your machine’s batch boxes. This list provides you with the documents’ file numbers so you can erase or print them as needed.

To print the list, press **MENU, 5, 1, 1, 5, ENTER**.

## Printing a document stored in a batch box

To print a document stored in a batch box:

- 1 Press **MENU, 4, 3, 0, 3, ENTER**. The LCD shows:

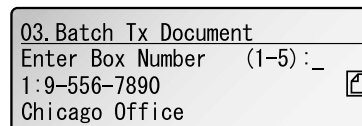

- 2 Use the numeric keypad to enter the number (1–5) of the batch box storing the document you want to print.

- 3 Press **ENTER**. The LCD shows:

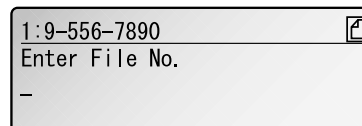

- 4 Use the numeric keypad to enter the document's file number (1-40).
- 5 Press **ENTER**.

Your fax machine prints the document, then returns to standby mode.

## Erasing a document stored in a batch box

To erase a document stored in a batch box on your fax machine:

- 1 Press **MENU, 4, 2, 0, 3, ENTER**. The LCD shows:

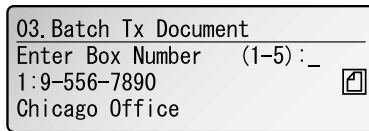

- 2 Use the numeric keypad to enter the number (1-5) of the batch box storing the document you want to erase.
- 3 Press **ENTER**. The LCD shows:

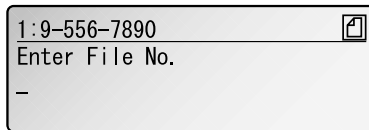

- 4 Use the numeric keypad to enter the document's file number (1-40).
- 5 Press **ENTER**. The fax machine now gives you one last chance to change your mind before erasing the document.

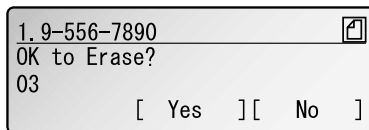

**Important:** To quit the operation without erasing this or any document, press **[No]**. The machine returns to standby mode.

- 6 Press **[Yes]**. The fax machine erases the document you've chosen. To return to standby mode, press **STOP**.

## Erasing an empty batch box

Batch boxes must be empty to be erased. If a box has documents stored in it, then you first have to erase those documents. See left column.

To erase an empty batch box:

- 1 Press **MENU, 3, 6, 0, 2, ENTER**. The LCD shows:

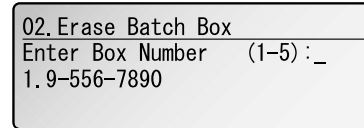

- 2 Use the numeric keypad to enter the number (1-5) of the batch box you want to erase.

- 3 Press **ENTER**. If the batch box is empty, the LCD shows:

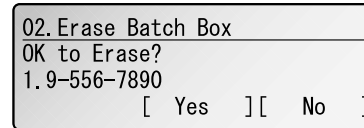

**Important:** If you want to quit without erasing the batch box you've selected, press **[No]**. The fax will return to step 2.

**Important:** If you want to quit without erasing *any* batch box, press **STOP**. The machine returns to standby mode.

**Important:** If you select a batch box which is *not* empty, the machine beeps and briefly shows:

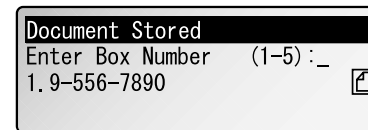

If the batch box is storing any documents, the  symbol is appeared on the LCD. Erase any documents stored in the box (see left column), then go back to step 1.

- 4 Press **[Yes]** to erase the batch box.

To erase another batch box, repeat steps 2-4. To finish, press **STOP**.

# Polling

*Polling* allows someone to fax a document to you *without* having to make the call or pay for it. There are two kinds of polling:

- Regular polling — Your fax retrieves a document from a remote fax machine.
- F-Code polling — Your fax retrieves a document stored as a file in the remote fax machine. To do this, you must be communicating with another F-code-compatible fax machine. For more information on F-Code polling, see “F-Code communication,” pages 3.37.

**Note:** For polling to work, the remote machine must also be set up to *be polled*.

---

## Regular polling

To set up your machine for regular polling:

- 1 Make sure the document is inserted in the remote fax machine.
- 2 Press **COMM. OPTIONS**. The LCD shows:

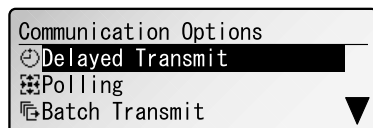

- 3 Select “**Polling**” and press **ENTER**. The LCD shows:

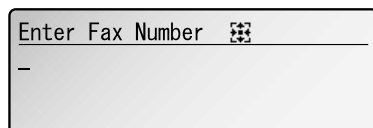

- 4 Enter the remote fax machine’s number by either pressing a one-touch key, entering a speed-dial number or using the numeric keypad.
- 5 To perform the regular polling *now*, skip to step 9. To perform *delayed* regular polling, go on to step 6.

- 6 Press **COMM. OPTIONS**, **ENTER**. The LCD shows:

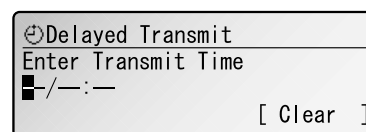

- 7 Use the numeric keypad to enter the date and time (use the *24-hour format*) when your machine should perform the delayed regular polling.
- 8 Press **ENTER**.
- 9 Press **START**.

When your machine polls for documents, it dials the number and, upon making contact with the other machine, begins receiving the document as if the other machine had placed the call.

---

## Being polled

Not only can you poll, but you can also *be* polled. To set up a document for regular polling:

- 1 If your fax machine is set for Tel Ready reception, change it to the reception mode except the Tel Ready.
 

**Important:** Your machine **can’t** be polled if it’s in Tel Ready mode.
- 2 Insert the document.
- 3 Adjust resolution and contrast if necessary. (Your fax machine will be transmitting to the machine doing the polling.)
- 4 Press **MENU**, **4**, **1**, **0**, **1**, **ENTER**. Your fax will scan the document into memory and return to standby mode.

Once the remote fax machine polls the document you stored, your fax machine automatically erases the document from memory.

## Printing a stored polling document

To print a document you've stored for regular polling *without erasing* it, press **MENU, 4, 3, 0, 1, ENTER**.

---

## Erasing a stored polling document

To erase a document you've stored for regular polling from your machine's memory:

- 1 Press **MENU, 4, 2, 0, 1, ENTER**. The LCD shows:

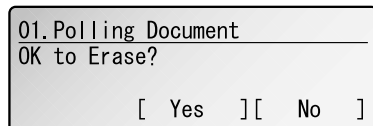

- 2 Press **[Yes]** to erase it.  
Press **STOP** to finish.

# Soft keys

Soft Keys are shortcut keys. You can assign some functions into these eight keys as you want. If the light above any one of these keys glows, that means the setting programmed into that key is active.

The following functions are assigned at the factory:

- Communication cancel / confirmation (see pages 2.6–2.7)
- Broadcast (see page 3.9)
- Communication options (to select advanced fax features)
- Dialing pause (to enter the dialing pause and the dialing characters. see page 2.2)
- Speed dial / Group (see pages 3.4–3.7)
- Monitor / Call request (see pages 2.4 and 3.26)
- Confirmation report (see page 3.23)\*
- Memory transmission (see page 2.2)\*

Other functions you can assign to the Soft Keys are as follows:

- Fax & Copy (see page 3.21)\*
- Send TTI (see page 4.2)\*
- Select usual TTI (see page 1.20)\*
- Security reception (see page 3.46)
- Cover page (see page 3.24)\*
- Auto answer (to toggle the Manual answer and Auto answer)
- Separator page setting for reception(see page 3.24)
- Select TO/CC/BCC (Available only when the optional Internet Fax kit is installed.)

\* When you change the setting by using the Soft Key, it will be available only for the next transmission. Once that transmission is complete, your machine returns to its default setting. If you want to change the default setting, see “Changing the default settings” on page 4.1–4.10

## Setting the Soft Key

- 1 Press **MENU**, **2**, **1**, **0**, **3**, **ENTER**. The LCD shows the function name currently stored in the Soft Key 1.

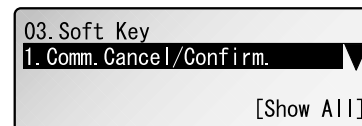

**Note:** If you want to see other functions currently stored in the Soft Keys, press **▼**. If you want to see all eight functions currently stored, press **[Show All]**. To return to the previous display, press **BACK**.

- 2 Press desired Soft Key (1–8) on the control panel you want to change. Then press **ENTER**. The functions you can assign to the Soft Key will appear:

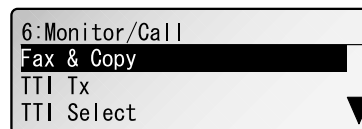

- 3 Using the cursor key, select the function you want.
- 4 Press **ENTER** to save the setting.
- 5 If you want to set another Soft Key, go back to step 2. If you *do not* want to set any more Soft Keys, press **STOP** to finish.

Now you can use the labels included in your machine’s original packaging to label the Soft Key function you just set.



# Special features

Your fax machine has numerous special features to make your communication easier. We'll cover them here.

## Macro keys

If you perform the same operation repeatedly, you can automate the operation using a macro. A macro is a series of the several steps that you group together as a single command to accomplish the operation automatically.

A macro key faithfully records up to 60 steps that you performed to teach the macro. You can “teach” the Macro keys to carry out any of the following jobs, but you cannot teach the operation regarding the machine settings.

**Note:** One Macro key can hold only one job. It cannot combine two or more jobs.

### Copy:

- All copy settings

### Printouts:

- Function list (page 1.13)
- User settings list (page 4.10)
- Activity journal (page 3.22)
- Delayed commands list (page 2.7)
- Delayed commands documents (page 2.7)
- One-touch list (page 3.3)
- Speed-dial list (page 3.5)
- Programmable one-touch numbers list (page 3.45)
- Call group directory (page 3.7)
- Blocked numbers list (page 3.51)
- Sample cover page (page 3.24)
- Department time list (page 3.53)
- List of F-Code boxes (page 3.32)
- List of documents stored in F-Code boxes (page 3.32)
- Batch transmission documents (page 3.13)
- Batch box list (page 3.13)

- List of stored batch documents (page 3.13)
- F-Code Box (bulletin box) documents (page 3.33)
- Macros list (page 3.21)
- Stored polling documents (page 3.16)
- Security receive documents (page 3.47)

### Document storage:

- Regular polling documents (page 3.15)
- F-Code polling documents (pages 3.32–3.34)

### Communications functions:

- Delayed transmission (explained on pages 3.11)
- Broadcasting (page 3.9)
- Regular polling (pages 3.15–3.16)
- Batch transmission (pages 3.12–3.14)
- F-Code transmission (page 3.36)
- F-Code polling (page 3.37)

## Programming the Macro key

- 1 Press **MACRO PROGRAM**. The LCD shows:

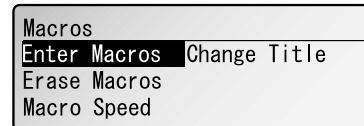

- 2 Select “**Enter Macros**” and press **ENTER**. The LCD shows:

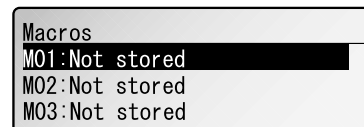

- 3 Press the Macro key (**M1**, **M2** or **M3**) you want to program or change. Then press **ENTER**. If you chose the key already programmed, proceed to step 4. Otherwise, skip to step 5.

4 The LCD shows:

```

Macros
-----
Overwrite?

[ Yes ] [ No ]
  
```

If you want to overwrite the operation already programmed, press **[Yes]**.  
 If you want to overwrite only the job's name, press **[No]** and go to step 8.  
 If you *do not* want to overwrite the key you have choice, press **STOP**.

5 Press the keys exactly as you operate the job you want to program into the Macro key.

**Note:** It keeps beeping during the job registration in order to make notice of the registration mode.

**Note:** You can program up to 60 steps. When it comes over 60 steps, your fax machine asks if you want to register the operations you have entered. If you want to register them, press **ENTER**. If not, press **STOP**.

**Note:** If you want to cancel the operations you have set, press **MACRO PROGRAM**, **STOP** and then go back to step 1.

*Example 1:* To program some operations for copy: Press **COPY** to change to the copy mode, and set number of the copies, contrast, resolution and reduction rate as you want.

**Note:** See "Making copies" (pages 2.10–2.11) for detail operations.

*Example 2:* To program the operations for printing the one-touch numbers list: Press **MENU**, **5**, **1**, **0**, **5**, **ENTER**.

6 If you programmed **ENTER** or **START** into the operation, proceed to step 7. Otherwise, press **MACRO PROGRAM** and skip to step 8.

7 If you want to start immediately after pressing the Macro key when you use it, press **[Yes]**. If not, press **[No]**.

**Note:** If you want to confirm the settings or operations in the Macro key before you start it, press **[No]** here.

```

Macros
-----
Include START/ENTER?

[ Yes ] [ No ]
  
```

8 The LCD now shows:

```

Macros
-----
Title          Lower Case
-
  
```

The machine now asks you to enter the title of this job.

If you *do not* want to enter or change it, skip to step 10.

9 Enter the title by using the numeric keypad. (If necessary, review "Entering characters", page 1.12) It may be up to 130 characters in length.

10 Press **ENTER** to save the setting.

## Changing the title of the Macro key

When you want to change only the title of a Macro key:

1 Press **MACRO PROGRAM**. The LCD shows:

```

Macros
-----
Enter Macros Change Title
Erase Macros
Macro Speed
  
```

2 Select "**Change title**" using the cursor key and press **ENTER**. The LCD shows:

```

Macros
-----
M01:Oversea Tx
M02:Copy 1
M03:Not stored
  
```

3 Press the Macro key (**M1**, **M2** or **M3**) you want to change. Then press **ENTER**. The LCD shows:

```

Macros
-----
Title          Lower Case
Copy 1_
  
```

4 Enter the new title by using the numeric keypad. (If necessary, review "Entering characters", page 1.12)

5 Press **ENTER** to save the setting.

## Copying with the Macro key

To copy using a Macro key:

- 1 Insert the document.
- 2 Press the **Macro key** in which you've stored the copy command.
- 3 Press **START**, if you have not registered **START** in the Macro key.

## Printing lists using the Macro key

To print a list using a Macro key:

- 1 Press the **Macro key** that is programmed for the printing lists.
- 2 Press **ENTER**, if you have not registered **ENTER** in the Macro key.

## Storing fax documents with the Macro key

To store a fax document for either polling or F-Code polling using a Macro key:

- 1 Insert the document.
- 2 Press the **Macro key** that is programmed for the storing operation you want to use.
- 3 Press **ENTER**, if you have not registered **ENTER** in the Macro key.

## Fax dialing with the Macro key

To dial a fax call using a Macro key:

- 1 Insert the document.
- 2 Press the **Macro key** in which you've stored the fax communication command.
- 3 Press **START**, if you have not registered **START** in the Macro key.

Your fax will perform the operation now, or at whatever time you programmed.

If you programmed this key to delay its operation, the LCD shows:

```
Ready to Fax      Reserved
Sep 25 2001 11:00am  Mem: 99%
                  Normal   Normal
                  [ Mode ] [Contrast]
```

If you programmed this key to perform the operation immediately after you press it, the LCD shows the number:

```
Press START Key
972-555-4335
   B4      Normal   Normal
          [ Mode ] [Contrast]
```

## Erasing a Macro key

- 1 Press **MACRO PROGRAM**. The LCD shows:

```
Macros
Enter Macros Change Title
Erase Macros
Macro Speed
```

- 2 Select "**Erase Macros**" and press **ENTER**. The LCD shows:

```
Macros
M01:Oversea Tx
M02:Copy 1
M03:Not stored
```

- 3** Press the Macro key (**M1**, **M2** or **M3**) you want to erase. Then press **ENTER**. The LCD shows:

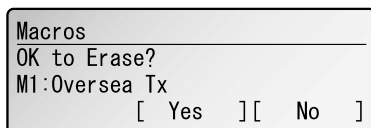

**Important:** If you want to quit without erasing the Macro key you've selected, press **[No]**. The machine will return to step 2.

- 4** Press **[Yes]** to erase the job.

To erase another Macro key, repeat steps 2–4. Or press **STOP** to return to standby mode.

## Printing a list of your Macro keys

Your fax machine can print a list of the Macro keys.

The list includes:

- (1) each key's Macro key number
- (2) the name of the job stored in the Macro key

To print a list of Macro keys, press **MENU**, **5**, **1**, **1**, **6**, **ENTER**.

## Setting the speed for Macros

You can adjust the speed of one step in the Macro key.

- 1** Press **MACRO PROGRAM**. The LCD shows:

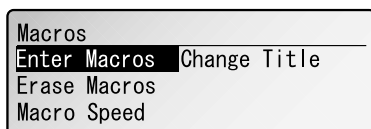

- 2** Select **"Macro Speed"** and press **ENTER**. The LCD shows:

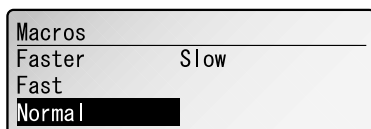

- 3** Select the mode you want.
- 4** Press **ENTER** to save the setting.

## Fax & Copy

With the Fax & Copy feature turned on, your machine asks if you want to make a copy of a document each time it transmits that document from memory.

**Note:** The Fax & Copy function cannot be used for real time transmission

**Note:** Quick Memory transmission (see page 2.2) and the Fax & Copy function cannot be used at the same time. If both are turned on, Quick Memory will not work.

**Note:** The Fax & Copy feature will use the same resolution you set for the transmission for the copy's scanning resolution.

## Setting the Fax & Copy function

- 1** Press **MENU**, **2**, **1**, **0**, **6**, **ENTER**. The LCD shows:

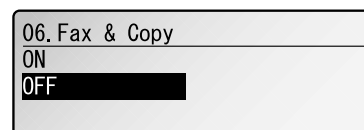

- 2** Using the cursor key, select the mode you want. Then press **ENTER**.

- 3** Press **STOP** to return to standby mode.

## Using the Fax & Copy function

- 1** Place the document and select resolution and contrast you require.
- 2** Enter the fax number. Either press a one-touch key, enter a speed-dial number, call group number or use the numeric keypad to enter the fax number.
- If you entered the fax number using a one-touch key, skip to step 4. Otherwise, go on to step 3.
- 3** Press **START**.
- 4** The LCD changes copy mode and asks the number of copies you want to make.

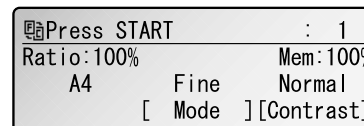

- 5** Use the numeric keypad to enter the number of copies you want for each page in the document. Choose from 01 to 99 copies.

## Advanced features

**Note:** If you want to quit without transmitting and copying the document, press **STOP**. The machine returns to standby mode.

**6** Press **START** to begin the transmission and copying process.

**Note:** If you do not wish to make a copy, press **CANCEL** in step 4. The LCD will show:

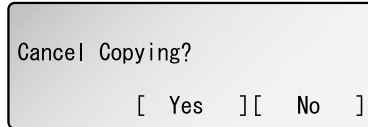

To cancel the making copy, press **[Yes]**. The machine start transmission process without copying the document.

If you press **[No]**, the machine return to step 4.

## Setting the journal and the report

You can turn the following three items on or off, regarding the *activity journal* and the *confirmation report (TCR)*:

- Automatic printing of the activity journal
- Printing order of the activity journal
- Automatic printing of the confirmation report (TCR)

### Automatic printing of the activity journal

Just as a checkbook records your daily financial transactions, your fax machine keeps an *activity journal* which records its 100 most recent fax transactions. The activity journal lists the following information for each transaction:

- *Assigned number*, starting each day at 001
- *Remote location* called
- *Resolution mode*
- *Starting date and time*
- *Duration*, in minutes and seconds
- *Length*, in number of pages
- *Department code* (see page 3.52)
- *Result of the call* — If preceded by an asterisk (\*), this signifies an ECM communication. If preceded by a pound (#), this signifies communication was via the highspeed V.34 modem.
- *Any special operations* — For example, a fax call made using an optional handset will appear as “Manual”

Your fax machine can print the activity journal automatically after 100 transactions. To turn this automatic printing of the activity journal on or off:

**1** Press **MENU, 3, 1, 0, 1, ENTER**. The LCD shows:

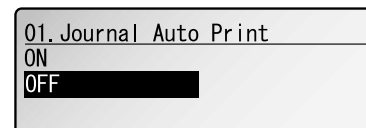

**2** Using the cursor key, select the mode you want. Then press **ENTER**.

### Printing an activity journal manually

To print an activity journal *immediately* without waiting for 100 transmissions to be completed, press **MENU, 5, 1, 0, 3, ENTER**.

## Setting the printing order of the activity journal

Your fax machine prints the activity journal for every fax transaction. For example, if your machine has to redial a call, it will list those redials on the journal.

If you want to list those activities in the order of their assigned numbers, you can change the printing order of the activity journal. To change the printing order:

- 1 Press **MENU, 3, 1, 0, 2, ENTER**. The LCD shows:

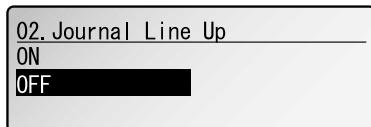

- 2 Using the cursor key, select the mode you want. If you want the activity journal to print in the order of assigned number, choose "ON". Otherwise, the machine will list every fax transaction of the same command and same location.
- 3 Press **ENTER** to save the setting.

## Setting the report: TCR

Your fax machine can print a *transmit confirmation report (TCR)* after sending every fax to *any* Group 3 fax machine. The TCR lists the following information for each communication:

- *Date and time* of the TCR's printout
- *Remote location* called
- *Resolution mode*
- *Starting date and time*
- *Duration*, in minutes and seconds
- *Length*, in number of pages
- *Result* of the call
- *Any special operations* — For example, a fax call made using an optional handset will appear as "Manual"
- *Sample of the document* — An image of the first page of the document

If an error occurs, the TCR tells you the remote location which was called, the *error code* and *error message* (see pages 5.8–5.10).

To turn this automatic printing of the TCR on or off:

- 1 Press **MENU, 3, 1, 0, 3, ENTER**. The LCD shows:

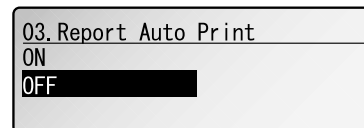

- 2 Using the cursor key, select the mode you want. Then press **ENTER**.

To turn the confirmation report feature on or off for *only* the next fax transmission, press **REPORT**.

What happens next depends on the setting you chose:

- If the light above the **REPORT** key glows, the fax machine will print the confirmation report automatically.
- If the light above the **REPORT** key doesn't glow, the fax machine will not print a confirmation report.

After you send this transmission, your machine returns to the setting you chose above.

## Separate each received document (Separator Page)

Your machine has a simple sorting feature. It can separate each received document by inserting the separator page on the top of the received document.

For example, if you use the colored paper for the separator page, it is easy to see the individual received document.

**Note:** You can assign the turning this feature on/off to a Soft Key. (See page 3.17.)

### Setting the *Separator Page* feature:

- 1 Press **MENU**, **2**, **2**, **1**, **2**, **ENTER**.

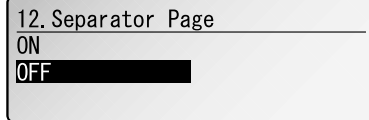

- 2 To turn the *Separator Page* feature on, select **“ON”** using the cursor key.

- 3 Press **ENTER**. The LCD will show:

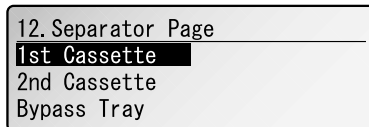

**Note:** The paper source which has not been attached to your machine will be not displayed on this list.

- 4 To select the paper source for the separator page using the cursor key.

- 5 Press **ENTER**. The LCD will show:

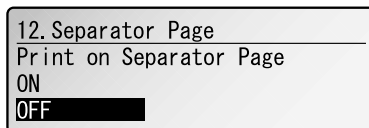

Determine if the separator page will be printed with blank or not. If you wish that the separator page will be blank, select **“OFF”**. If you wish to print the first page of the received documents on the separator page, select **“ON”**.

### Separator page separates each received document.

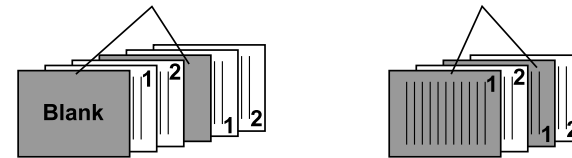

Print on the separator page: **OFF**

Print on the separator page: **ON**

- 6 Press **ENTER** to save the settings.

To return to standby mode, press **STOP**.

## Cover page

Your fax machine can store a *cover page* to send at the beginning of each outgoing fax. This page includes the current date and time, your Location ID, your fax number (as stored in the TTI) and a message of up to 40 characters in length. The information appears in a box similar to this:

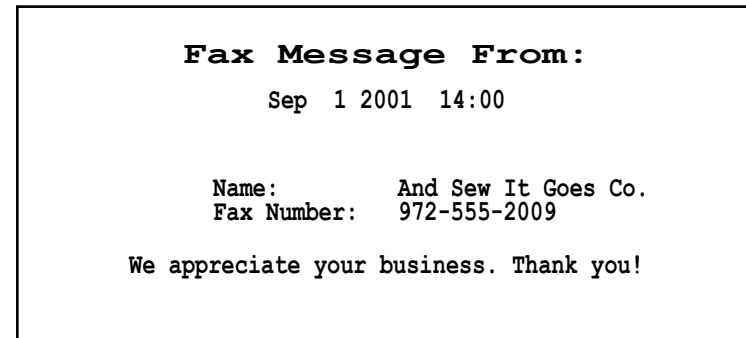

## Turning the cover page on

- 1 Press **MENU, 3, 2, 0, 1, ENTER**. The LCD shows:

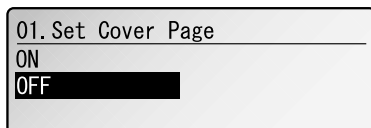

- 2 To tell the fax machine it *should* send a cover page before each document you transmit, select **“ON”** using the cursor key.

**Note:** To tell the machine not to send a cover page, select **“OFF”**.

- 3 Press **ENTER** to save the setting.

Now the cover page feature is working but your message line (shown in the example as “We appreciate your business. Thank you!”) is blank. To enter that message, see “Entering the cover page message,” below.

## Entering the cover page message

- 1 Press **MENU, 3, 2, 0, 2, ENTER**. The LCD shows:

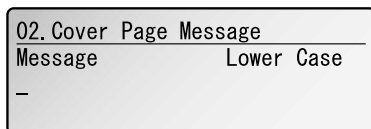

- 2 Use the numeric keypad to enter a message for the cover page. (Regarding how to enter the character, see “Entering character” on page 1.12.) The message can be up to 40 characters in length.
- 3 When the message appears as you want it, press **ENTER** to save it.

## Printing the cover page

To confirm that the cover page is set correctly, print a sample cover page from your fax machine. Press **MENU, 5, 1, 0, 9, ENTER**.

## OneLine + distinctive ring detection

Many phone companies now offer their customers a special service which makes it possible for one phone line to do the work of two.

With this service, you physically still have one phone line, but, electronically, you have two phone *numbers*. Your phone recognizes these different numbers and rings differently for each one.

For example, this makes it easy for you to have both a business number and a home number on one phone line, so you can answer one with “Jane Doe Consulting,” and the other with “Hello.” This works because you can tell the difference between the distinctive *patterns* of the two rings.

Your fax machine is also smart enough to tell the difference between two different numbers that are ringing it. All you have to do is set up your machine for the *OneLine + distinctive ring detection (DRD) feature*.

In order to use OneLine + DRD, your phone company must set up your distinctive ring service. When it does, it will assign a *ring pattern*. For example, the standard telephone ring is 2 seconds “on” (ringing) and 4 seconds “off” (silent), after which it repeats itself.

Your fax has eight possible distinctive ring patterns for use with OneLine + DRD. One of them should work with your phone company’s DRD service. This chart lists the patterns:

Pattern	One complete ring pattern (seconds)
<b>A</b>	0.8 on, 0.4 off, 0.8 on, 4.0 off
<b>B</b>	0.4 on, 0.2 off, 0.4 on, 0.2 off, 0.8 on, 4.0 off
<b>C</b>	0.3 on, 0.2 off, 1.0 on, 0.2 off, 0.3 on, 4.0 off
<b>D</b>	1.0 on, 0.5 off, 1.0 on, 3.5 off
<b>E</b>	0.5 on, 0.5 off, 0.5 on, 0.5 off, 1.0 on, 3.0 off
<b>F</b>	0.5 on, 0.5 off, 1.0 on, 0.5 off, 0.5 on, 3.0 off
<b>G</b>	0.4 on, 0.6 off, 0.4 on, 4.6 off
<b>H</b>	1.5 on, 0.5 off, 0.5 on, 3.5 off

For example: pattern C is 0.3 seconds ringing, 0.2 seconds silent, 1 second ringing, 0.2 seconds silent, 0.3 seconds ringing and 4 seconds silent. Then it goes back to the first 0.3-second ring and starts over.



## Advanced features

To use DRD on your fax machine:

**1** Contact your phone company to make sure it has set up DRD service for you. If possible, also find out which distinctive ring pattern the phone company has assigned you.

**2** Press **MENU, 2, 2, 1, 5, ENTER**. The LCD shows:

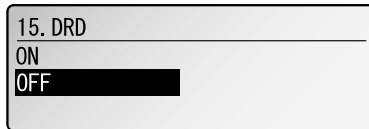

**3** Using the cursor key, select the mode you want.

**4** Press **ENTER**. The LCD shows:

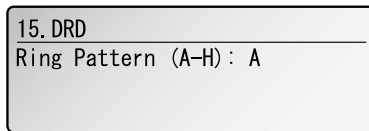

**5** Pressing **▲** or **▼**, select the pattern you want.

**6** Press **ENTER** to set your machine to the displayed ring pattern.

**Important:** If your telephone company gives you only very general ring pattern specifications, or if you encounter a problem while using your machine's DRD feature, **please try ALL of the listed ring patterns**. If you still have a problem after trying **all** of the patterns, please call the Muratec Customer Support Center. (From the United States, call 800-347-3296.)

**Important:** With your machine set for using DRD, it won't respond to any ring pattern other than the one you selected above. To reset the fax so it will respond once again to normal rings, select "**OFF**" in step 3 above. Your fax will now respond normally.

## Call request

You can send or receive a fax message *and* have a regular phone conversation *on the same call* (although, not at the same time). This is called a *call request*. It doesn't matter whether you're sending the fax or receiving it. You may fax first and then talk, or talk first and then fax.

**Important:** For this feature to work, the remote fax machine must have a similar call-request capability. Your machine must also have an optional handset attached.

### Faxing/receiving first, then talking

To send or receive a fax first and then talk:

- 1** While your fax machine is sending or receiving the fax, press **MONITOR/CALL**.
- 2** At the remote fax machine, the ringer will sound after that machine receives each page.
- 3** If someone answers at the remote fax machine, your fax machine will ring several times. If so, pick up the optional handset. In a few seconds, the line will open and you can begin your conversation.

### Talking first, then *sending* a fax

To talk first and then send a fax:

- 1** When you've finished your phone conversation, *don't hang up*.
- 2** Insert the document you want to fax.
- 3** Adjust the resolution and contrast if necessary.
- 4** Tell the person at the other fax machine to press **START** and to hang up his/her handset. *Don't hang up **your** handset yet!*
- 5** When you hear fax tones, press **START** and hang up your fax machine's optional handset. Your fax machine will send the document.

### Talking first, then *receiving* a fax

To talk first and then receive a fax:

- 1** When you've finished your phone conversation, *don't hang up*.
- 2** Tell the person at the other fax machine to press **START** and to hang up his/her handset. *Don't hang up your handset yet!*
- 3** When you hear fax tones, press **START** and hang up your machine's optional handset. Your machine will receive the document and print it out.

## Responding to a call request

If someone requests a call *from* you during a fax communication, you'll hear a long ring after the receiving machine has received each page. To answer the call request:

- 1 Lift your machine's optional handset, and listen for a few seconds. You may hear a brief series of fax tones.
- 2 Shortly, the line will open and the person at the other end of the line will answer. You and the other person now can have a normal phone conversation.

---

## The power of QuadAccess®

Your fax machine's *QuadAccess* feature sharply reduces the time you might spend waiting for the machine to finish its work. QuadAccess is a more powerful version of what already is a pretty powerful feature, called *dual access*. While a fax with normal dual access allows you to do two things at once, QuadAccess allows you to do *four* operations at once. *For example*, even if the machine is (1) printing a copy, (2) transmitting from memory and (3) scanning documents for a different memory transmission, you can still (4) program the machine.

## F-Code Boxes

### F-Code: an introduction

The ITU-T, the United Nations agency that standardizes international telecommunications, has created a fax industry standard for using sub-addressing and password-based communication. One name for this standard is F-Code, and that's what we'll call it in these instructions and on your machine's display.

#### *How sub-addressing works*

To help understand sub-addressing, think about how someone in a large company receives mail. For example, mail for the Accounting department is first delivered to the company's main mailroom. Then the mailroom routes the mail to Accounting.

That's the idea behind sub-addressing. Your fax and another F-Code-compatible fax exchange special signals to indicate just where the fax really should go. It's as if the sending fax is saying, "Deliver this to room 48," and the receiving fax does just that.

Your machine has up to 50 mailboxes for these special deliveries. When someone sends an F-Code fax to you, your machine receives it into one of those 50 mailboxes — whichever box the sender chooses.

#### *Sending F-Code securely*

For greater security, you can set up a password with each F-Code sub-address, which lets you use secure transmission, polling and relay broadcasting when communicating with any other F-Code compatible fax machine.

#### *Guidelines for using F-Code*

- (1) To use ITU-T sub-addressing, you must create F-Code boxes in your machine
- (2) Your machine holds up to 50 of these boxes
- (3) Your machine stores up to 30 documents into each F-Code box (each document can include one or more pages)

## Creating or modifying an F-Code box

### *Choosing the F-Code box type*

Before you set up an F-Code box, first decide how your callers will use it — as a bulletin box, a security box or a relay box.

- **Bulletin box** — Stores documents that people in remote locations retrieve by *polling* the box. For example, your sales branches could call in at any time to get a printout of your latest prices that you've stored in a bulletin box.  
A bulletin box stores both scanned and retrieved documents, and it holds its contents indefinitely (as long as the unit has AC power).
- **Security box** — Receives and stores F-Code secure communications.

## Advanced features

- **Relay box** — Receives documents, then relays them to other machines. The machine that relays the document is called a “hub”. Your fax machine can either *send* to a hub or it can *be* a hub.

### 4 elements of an F-Code box

Each F-Code box has the following four elements:

- (1) F-Code box number (01-50)
- (2) F-Code box name (up to 16 characters)
- (3) F-Code sub-address (up to 20 characters - can include numbers and the \* and # characters only)
- (4) I.D. Code (4 digits)

You will choose the information for each of these elements, and enter it into your machine. The following steps will walk you through entering and changing that information.

### To create or modify an F-Code box:

- 1 Keep pen and paper with you as you follow these steps. As you decide on a sub-address and enter it into your machine, write it down. Remember to: (1) write down which box goes with which sub-address, (2) write down any passwords or I.D. codes you enter, (3) keep these printed records in a safe place.
- 2 Press **MENU, 3, 5, 0, 1, ENTER**. The LCD shows:

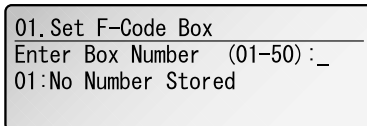

01. Set F-Code Box  
Enter Box Number (01-50) : \_  
01:No Number Stored

- 3 Use the numeric keypad to enter the two-digit number (01-50) of the F-Code box you want to create or modify.
- 4 Press **ENTER**. What you do next depends on whether you’re creating or modifying the F-Code box:  
If creating — skip to step 6.  
If modifying — the LCD asks you to enter the proper I.D. code. The LCD shows:

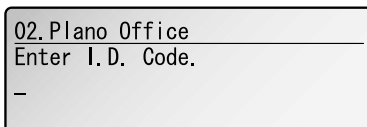

02. Plano Office  
Enter I.D. Code.  
-

- 5 Use the numeric keypad to enter the 4-digit I.D. code (not the ITU-T sub-address and not the ITU-T password). Skip to step 7.

**Note:** If you enter an invalid I.D. code, the fax machine rejects the attempt and aborts this operation.

**Note:** If you want to modify an existing F-Code box and want to change the box *type*, you first must erase the old box, then create a new one.

- 6 The LCD now shows:

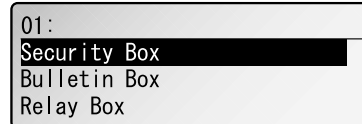

01:  
Security Box  
Bulletin Box  
Relay Box

The fax machine is asking which box type you want to assign to this box — *security*, *bulletin* or *relay*. Select the type of box you want.

- 7 Press **ENTER**.  
If you chose *Security*, go on to step 8.  
If you chose *Bulletin*, skip to step 22.  
If you chose *Relay*, skip to step 36.

### If you chose Security:

- 8 The LCD shows:

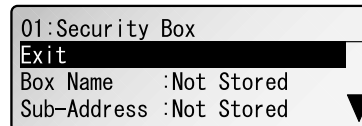

01:Security Box  
Exit  
Box Name :Not Stored  
Sub-Address :Not Stored

- 9 Select “**Box Name**” and press **ENTER**. The LCD shows:

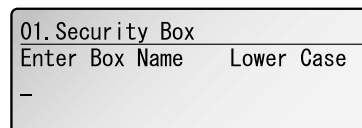

01. Security Box  
Enter Box Name Lower Case  
-

- 10 Enter the name by using the numeric keypad. (If necessary, review “Entering characters”, page 1.12) An F-Code box’s name can be up to 16 characters in length.

- 11 Press **ENTER**. The LCD shows:

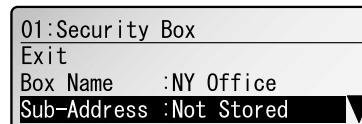

01:Security Box  
Exit  
Box Name :NY Office  
Sub-Address :Not Stored

- 12** Select “**Sub-Address**” and press **ENTER**. The LCD shows:

```
01. Security Box
Enter Sub-Address
-
```

The fax machine asks for this F-Code box’s sub-address. This is the numerical identifier you must enter in order to communicate with any remote F-Code compatible fax.

If you do not want to change an existing sub-address, skip to step 14.

- 13** Use the numeric keypad to enter the sub-address to identify this F-Code box. The sub-address can be up to 20 characters in length and include any combination of numbers and the \* and # characters (but no other non-numeric characters).

**Note:** No other F-Code box in this machine can have the same sub-address as the one you enter here.

- 14** Press **ENTER**.

**Note:** If you entered a sub-address already being used by another F-Code box, the machine beeps and briefly displays:

```
Already Stored
Enter Sub-address
-
```

The machine now returns you to step 12. Please enter a different number for your F-Code box’s sub-address.

- 15** The LCD shows:

```
01:Security Box
Password :Not Stored ▲
Hold Time :00 days
```

**Note:** You don’t need to have a password for the F-Code box. However, using a password will make your F-Code communication much more secure.

If you *do not* want to enter or change this box’s password, skip to step 18.

- 16** Select “**Password**” and press **ENTER**. The LCD shows:

```
01. Security Box
Enter Password
-
```

- 17** Use the numeric keypad to enter this box’s ITU-T-compatible password. This password can be up to 20 characters in length and include any combination of numbers and the \* and # characters (but no other non-numerical characters).

- 18** Press **ENTER**. The LCD shows:

```
01:Security Box
Password :123456 ▲
Hold Time :00 Days
```

- 19** Select “**Hold Time**” and press **ENTER**. The LCD shows:

```
01. Security Box
Enter Doc. Hold Time (00-31)
00
```

The fax machine now asks how long you want to keep a document stored in your machine’s F-Code box.

- 20** Use the numeric keypad to enter a two-digit number indicating how many days (00-31) you want your fax machine to keep received documents in this F-Code box.

**Note:** Your fax machine can store incoming documents in F-Code boxes (up to 30 documents) as long as 31 days, after which it automatically erases the documents. But if your machine has plenty of memory, you may want to override the 31-day limit in order to keep the documents indefinitely. If so, enter 00. If you choose this, you will have to delete documents manually. (You may want to contact your authorized Muratec dealer regarding optional memory expansion.)

- 21** When the number you want appears, press **ENTER**. Skip to step 46.

**If you chose Bulletin:**

**22** The LCD shows:

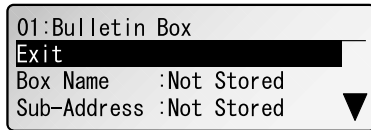

**23** Enter the box name, the sub-address and the password for the F-Code box as described in steps 8-17.

**24** Press **ENTER**. The LCD shows:

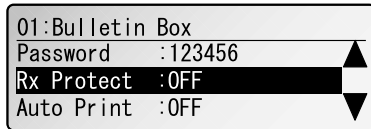

**25** Select **“Rx Protect”** and press **ENTER**. The LCD shows:

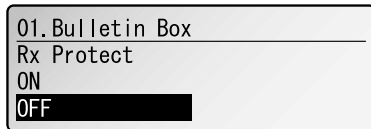

*Reception protection* tells this box if it's okay to receive documents from remote locations. Callers can then poll these documents.

ON (protect on): *Do not* open this box to receive documents from callers.  
OFF (protect off): *Open* this box to receive documents from callers.

**26** Using the cursor key, select the mode you want.

**27** Press **ENTER**. The LCD shows:

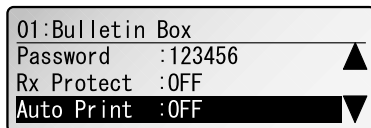

**28** Select **“Auto Print”** and press **ENTER**. The LCD shows:

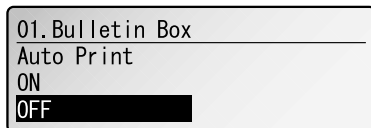

*Automatic printing of received documents* tells the fax machine if it should print a document automatically upon receiving it into this box.

**Note:** This setting is available only when the reception protection (*Rx protect*) setting is set to *off* (see above).

ON: Print the document automatically when the box receives it.  
OFF: Print the document manually, when you want to print it.

**29** Using the cursor key, select the mode you want.

**30** Press **ENTER**. The LCD shows:

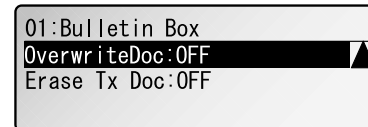

**31** Select **“OverwriteDoc”** and press **ENTER**. The LCD shows:

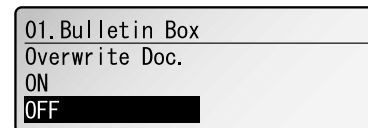

*Overwriting documents* tells your machine if it should overwrite (erase) existing documents when it receives a new one.

**Note:** This setting is available only when the reception protection setting is set to off (see *Rx Protect* above).

ON: When your machine receives a new document into this box, it will erase any documents currently stored in it.

OFF: When your machine receives a new document into this box, it *will not* erase the documents stored in it. Your machine can store up to 30 *documents* (each document can include one or more pages) in each box.

**32** Using the cursor key, select the mode you want.

**33** Press **ENTER**. The LCD shows:

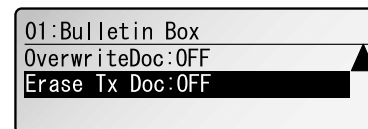

- 34** Select **“Erase Tx Doc”** and press **ENTER**. The LCD shows:

```

01:Bulletin Box
Erase Tx Doc.
ON
OFF
  
```

*Erasure of transmitted documents* tells your machine if it should erase a document from the box after a caller retrieves (polls) the document.

- ON:** Your machine erases the document from the box as soon as it sends it. If you choose “On”, this box can be polled only once per document.
- OFF:** Your machine does not erase a document from the box when it’s polled. As long as your machine holds AC power and you do not erase the document from the box, the document is available indefinitely for polling.
- 35** Using the cursor key, select the mode you want. Press **ENTER** and skip to step 46.

*If you chose Relay:*

- 36** The LCD shows:

```

01:Relay Box
Exit
Box Name :Not Stored
Sub-Address :Not Stored
  
```

- 37** Enter the box name, the sub-address and the password for the F-Code box as described in steps 8-17.

- 38** Press **ENTER**. The LCD shows:

```

01:Relay Box
Password :123456
Location :Not Stored
TTI Type :Sender
  
```

- 39** Select **“Location”** and press **ENTER**. The LCD shows:

```

01:Relay Box
Enter Fax Number
-
  
```

Enter the fax number using a one-touch key, a speed-dial number or a call group number. You cannot use the numeric keypad to enter these numbers. You can specify up to 300 numbers for a remote unit.

**Note:** If you want to review the numbers you entered, press **[Review]**.

```

G01
db02:NY Office
db01:Plano Office
[ Return ] [ Erase ]
  
```

If you want to erase any number, move the cursor on it and press **[Erase]**.

When you finish to review, press **[Return]** to return to the previous display.

- 40** Press **ENTER**. The LCD shows:

```

01:Relay Box
Password :123456
Location :db01,db03,S001
TTI Type :Sender
  
```

- 41** Select **“TTI Type”** and press **ENTER**. The LCD shows:

```

01:Relay Box
TTI Type
Sender Yours
Both
  
```

The machine asks for the type of TTI you want to appear on the faxes that are relayed to other callers.

- **Sender** — Relay the document with sender unit’s TTI (*don’t* send your TTI).
- **Both** — Relay the document with both the sender unit’s TTI and your TTI.
- **Yours** — Relay the document with your TTI instead of the sender unit’s.

- 42** Using the cursor key, select the mode you want.

- 43** Press **ENTER**. The LCD shows:

```

01:Relay Box
Auto Print :OFF
  
```

- 44** Select **“Auto Print”** and press **ENTER**. The LCD shows:

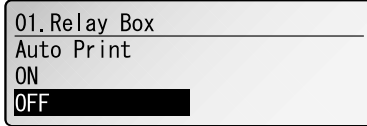

ON: Print the document automatically when it's received.  
 OFF: The machine does not print it, but only relays it to the other machine.

- 45** Using the cursor key, select the mode you want. Then press **ENTER**.

- 46** Select **“Exit”** and press **ENTER**. The LCD shows:

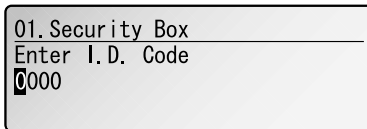

The machine asks for your F-Code box's four-digit security I.D. code. This is the I.D. code for the box's security, which you use to: (1) print a document any remote F-Code-compatible fax sends to this F-Code box, or (2) you enter before you can make any changes to this F-Code box.

If you do not want to change the I.D. code, skip to step 49.

- 47** Decide on a four-digit I.D. code (0001-9999) for this F-Code box. **Write it down**, and put it in a safe place.

**Important:** Do not use 0000 as an I.D. code.

- 48** Use the numeric keypad to enter the four-digit I.D. code for this F-Code box.

**Important:** After completing this step, you must know this code to print documents sent to this F-Code box. Be sure to write it down.

- 49** Press **ENTER**.

To create or modify another F-Code box, repeat steps 3-49.  
 To finish, press **STOP**.

## Printing a list of F-Code boxes

The list of F-Code boxes includes:

- (1) Each box's identifier number
- (2) Box name (if any)
- (3) Sub-address
- (4) Password
- (5) Box type
- (6) Each box's settings

To print a list of your F-Code boxes, press **MENU, 5, 1, 1, 2, ENTER**.

## Printing a list of documents stored in your F-Code boxes

The list of documents stored in your machine's F-Code boxes includes:

- (1) Each box's identifier number
- (2) Box name (if any)
- (3) Box type
- (4) Each file number (or document number) that is stored

To print a list of documents stored in F-Code boxes, press **MENU, 5, 1, 1, 3, ENTER**.

## Using a bulletin box

### Storing a document

Your fax machine can store up to 30 *documents* in each bulletin box.

**Note:** For this operation to work, two things must be true:

- The bulletin box must exist on your fax machine.
- You must know the bulletin box's two-digit number (01-50) and four-digit I.D. code. (See "Creating or Modifying an F-Code box," pages 3.28–3.32, if necessary.)

To store a document in a bulletin box for polling.

- 1** Insert the document and make any necessary adjustments.

- 2** Press **MENU, 4, 1, 0, 2, ENTER** The LCD shows:

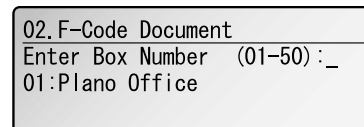

- 3** Use the numeric keypad to enter the two-digit identifier number (01-50) of the F-Code box where you want to store the document.

- 4** Press **ENTER**. The LCD shows:

```
01. Bulletin Box
Enter I. D. Code
_
```

- 5** Use the numeric keypad to enter the four-digit I.D. code.
- 6** Press **ENTER**.  
If you've entered an incorrect I.D. code, your fax machine rejects the attempt and returns to standby mode.  
If you've entered the correct I.D. code, the display shows:

```
01. Bulletin Box
Select Store Method
Overwrite
Add
```

If you choose:

- Overwrite:** Your bulletin box erases the currently stored document when a new document is stored in it
- Add:** Your bulletin box keeps both the currently stored document and the new document, up to 30 documents in each box.

- 7** Using the cursor key, select the mode you want.
- 8** Press **ENTER** to save the setting. Your machine starts scanning the document into the selected bulletin box:
- Important:** The file number (shown above as *1*) tells you how many documents are in this bulletin box. Your machine numbers files *1-30*. You need to know the file's number to erase or print it.

### Printing a document stored in a bulletin box

You can print a document stored in your machine's F-Code bulletin boxes without erasing the document from memory.

To print a stored document:

- 1** Press **MENU, 4, 3, 0, 2, ENTER** The LCD shows:

```
02. F-Code Document
Enter Box Number (01-50) : _
01:Plano Office
```

- 2** Use the numeric keypad to enter the two-digit number (*01-50*) of the F-Code bulletin box that stores the document you want to print.

**Note:** If the F-Code box is storing any documents, the  symbol is appeared on the LCD.

- 3** Press **ENTER**. The LCD shows:

```
01. Bulletin Box
Enter I. D. Code
_
```

- 4** Use the numeric keypad to enter your F-Code box's four-digit I.D. code.

- 5** Press **ENTER**.  
If you've entered an incorrect I.D. code, your fax machine rejects the attempt and aborts this operation.  
If you've entered the correct I.D. code, the display shows:

```
01. Bulletin Box
Enter File Number (00-30) : _
00:All Stored Documents
```

- 6** Use the numeric keypad to enter the file number (*01-30*) of the document you want to print.
- Note:** If you want to print *all* documents stored in the bulletin box, enter *00* (zero).

- 7** Press **ENTER**.  
Your fax machine prints the chosen document(s), then returns to standby mode.

### Erasing a document stored in a bulletin box

To erase a stored document:

- 1** Press **MENU, 4, 2, 0, 2, ENTER** The LCD shows:

```
02. F-Code Document
Enter Box Number (01-50) : _
01:Plano Office
```



- 2 Use the numeric keypad to enter the two-digit number (01-50) of the F-Code bulletin box that stores the document you want to erase.

**Note:** If the F-Code box is storing any documents, the  symbol is appeared on the LCD.

- 3 Press **ENTER**. The LCD shows:

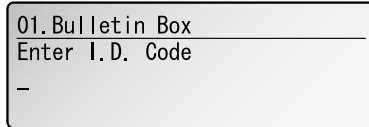

- 4 Use the numeric keypad to enter your F-Code box's four-digit I.D. code.

- 5 Press **ENTER**.  
If you've entered an incorrect I.D. code, your fax machine rejects the attempt and aborts this operation.  
If you've entered the correct I.D. code, the display shows:

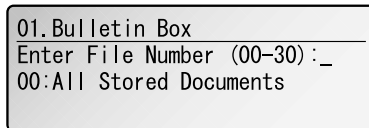

- 6 Use the numeric keypad to enter the file number (01-30) of the document you want to erase.

**Note:** If you want to erase *all* documents stored in the bulletin box, enter 00 (zero).

- 7 Press **ENTER**. The LCD shows:

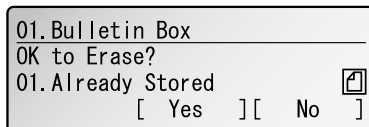

**Note:** If you want to quit without erasing the file you've selected, press **[No]**. The fax will return to step 2.

**Note:** If you want to quit without erasing *any* document in the bulletin box, press **STOP**. The machine will return to standby mode.

- 8 Press **[Yes]** to erase the document(s) and to return to standby mode.

## Using a security box

### Printing a document you receive

When your fax machine receives a document via ITU-T sub-addressing to an F-Code security box, your machine prints a message to let you know. The message lists: (1) the F-Code box number that received the document, (2) the Box name, (3) the remote machine's TTI (if any), and (4) the file numbers stored in the F-Code box.

You then have a certain number of days (see step 19 and 20 on page 3.29) in which to print out the document before your machine automatically erases it.

**Note:** For this operation to work, two things must be true:

- You must know the F-Code security box's two-digit number.
- You must know the F-Code security box's four-digit I.D. code.

To print a received message:

- 1 Press **MENU, 4, 3, 0, 2, ENTER**. The LCD shows:

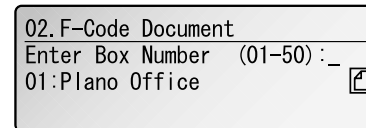

- 2 Use the numeric keypad to enter the two-digit number (01-50) of the F-Code security box that stores the document you want to print.

**Note:** If the F-Code box is storing any documents, the  symbol is appeared on the LCD.

- 3 Press **ENTER**. The LCD shows:

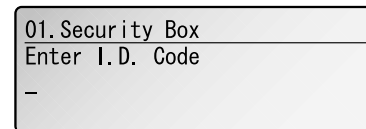

- 4 Use the numeric keypad to enter your F-Code box's four-digit I.D. code.

- 5 Press **ENTER**.
  - If you've entered the correct I.D. code, your fax machine prints all documents in the F-Code security box and then erases them.
  - If you've entered an incorrect I.D. code, your fax machine aborts the operation and returns to standby mode.

## Using a relay box

Once your fax machine receives a document via ITU-T sub-addressing to one of its F-Code relay boxes, it sends it to the other fax machines that you've set up on your relay box. (See "Creating or Modifying an F-Code box", pages 3.28–3.32.)

If you set the Auto print mode to *on* when you created the relay box, your machine will *print* the received document, then relay it to the other machine. Otherwise, your machine will *only relay* it to the other machines, not print it. See "If you chose Relay," page 3.31 for more details on this setting.

Also, you can send (*relay broadcast initiation*) the document to another hub machine's F-Code box and get that machine to relay it to others. See "F-Code transmission" on page 3.36 for more detail.

The hub performs a *relay broadcast*, and the machine which sends the original document to the hub has performed a *relay broadcast initiation*.

## Erasing an empty F-Code box

An F-Code box must be empty in order to erase it. (If you select an F-Code box in these steps which is not empty, the machine beeps. If this happens, print all documents in that box before erasing it.)

To erase an empty F-Code box:

- 1 Press **MENU, 3, 5, 0, 2, ENTER**. The LCD shows:

```
02. Erase F-Code Box
Enter Box Number (01-50) : _
01:Plano Office
```

- 2 Use the numeric keypad to enter the two-digit identifier number (01-50) of the F-Code box you want to erase.

**Note:** If the F-Code box is storing any documents, the  symbol is appeared on the LCD.

- 3 Press **ENTER**. If the F-Code box is empty, the LCD shows:

```
01. Plano Office
Enter I.D. Code
_
```

**Important:** If you select an F-Code box which is *not* empty, the machine beeps and, before returning to step 2, briefly displays:

```
Box In Use
Enter Box Number (01-50) : _
01:Plano Office
```

Print any documents received in the F-Code box, then repeat this procedure from the beginning to erase the box. Otherwise, select another F-Code box.

- 4 Use the numeric keypad to enter the four-digit I.D. code.
- 5 Press **ENTER**.  
If you've entered an incorrect I.D. code, your fax machine rejects the attempt and returns to standby mode.  
If you've entered the correct I.D. code, the display shows:

```
01. Plano Office
OK to Erase?
[ Yes ] [ No ]
```

**Note:** If you want to quit without erasing the F-Code box you've selected, press **[No]**. The fax will return to step 2.

**Note:** If you want to quit without erasing *any* F-Code box, press **STOP**. The machine returns to standby mode.

- 6 Press **[Yes]** to erase the F-Code box.  
To erase another F-Code box, repeat steps 2-6.  
To finish, press **STOP**.

## F-Code transmission and polling

With F-Code, your machine can send secure transmissions, perform relay broadcast initiations and even poll from other ITU-T-equipped machines, regardless of manufacturer.

You can do this two ways:

- Using the programmable one-touch key (see pages 3.41–3.42)
- Entering the ITU-T sub-address and password directly, which is what we'll describe here.

**Note:** For F-Code communication to work, three things must be true:

- The remote fax machine must support ITU-T sub-addressing
- The remote fax must have a mailbox with an ITU-T sub-address created on it
- You must know the ITU-T sub-address and password (if any) for the remote machine's mailbox

## F-Code transmission

- 1 Insert the document.
- 2 Adjust the resolution and contrast if necessary.
- 3 If you want to toggle between real time transmission and memory transmission, press **MEMORY TRANSMIT**.
- 4 Press **COMM. OPTIONS**. The LCD shows:

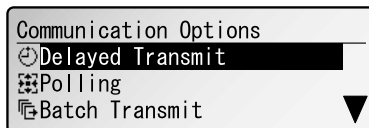

- 5 Select "**F-Code Transmit**" and press **ENTER**. The LCD shows:

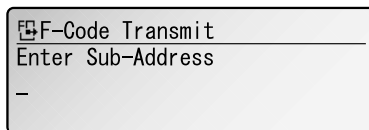

- 6 Use the numeric keypad to enter the appropriate sub-address in the remote machine.

**Note:** If you make a mistake, press **CANCEL** to erase the character, then enter the correct number.

- 7 Press **ENTER**. The LCD shows:

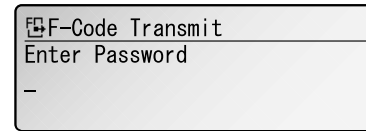

**Note:** If this sub-address does not have a password, skip to step 9.

- 8 Use the numeric keypad to enter the password.

- 9 Press **ENTER**. The LCD shows:

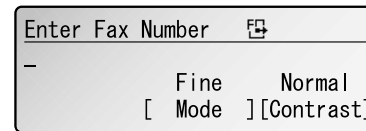

- 10 Enter the fax number either by pressing a one-touch key, entering a speed-dial number or dialing from the numeric keypad. Do **not** press **START**.

- 11 What you do now depends on when you want the transmission to begin.

- To have it begin *now*, skip to step 14.
- To delay it, go on to step 12.

- 12 Press **COMM. OPTIONS**, **ENTER**. The LCD shows:

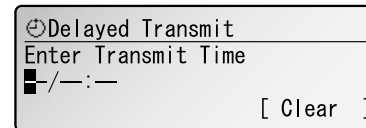

- 13 Use the numeric keypad to enter the day and time when the transmission should begin, then press **ENTER**.

- 14 Press **START**.

If in step 11 you chose an immediate transmission, your fax machine begins dialing. If you chose a delayed command, the machine shows "Reserved" on the LCD, indicating that it has stored the command in memory and will complete it later.

## F-Code polling

**1** Press **FAX** to switch the machine to Fax mode.

**2** Press **COMM. OPTIONS**. The LCD shows:

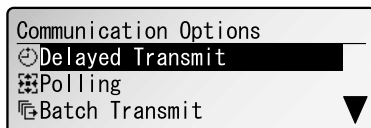

**3** Select "**F-Code Polling**" and press **ENTER**. The LCD shows:

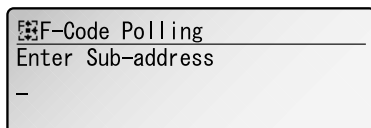

**4** Use the numeric keypad to enter the appropriate sub-address.

**Note:** If you make a mistake, press **CANCEL** to erase the character, then enter the correct number.

**5** Press **ENTER**. The LCD shows:

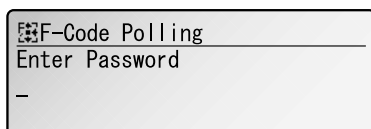

**Note:** If this sub-address does not have a password, skip to step 7.

**6** Use the numeric keypad to enter the password.

**7** Press **ENTER**. The LCD shows:

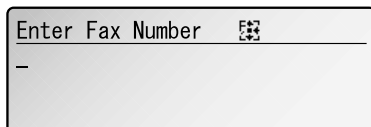

**8** Enter the fax number either by pressing a one-touch key, entering a speed-dial number or dialing from the numeric keypad. Do **not** press **START**.

**9** What you do now depends on when you want the polling to begin.

- To have it begin *now*, skip to step 12.
- To delay it, go on to step 10.

**10** Press **COMM. OPTIONS**, **ENTER**. The LCD shows:

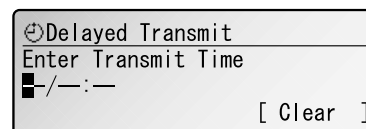

**11** Use the numeric keypad to enter the day and time when the polling should begin, then press **ENTER**.

**12** Press **START**.

If in step 9 you chose an immediate polling, your fax machine begins dialing. If you chose a delayed command, the machine shows "Reserved" on the LCD, indicating that it has stored the command in memory and will complete it later.

## Programmable one-touch keys

### Using the power of programmable one-touch keys

In order to complete some operations on your machine, you may have to follow several steps and press several different buttons. But programming your machine's *one-touch keys* (57 to 60) can reduce those many steps to a simple press of a key. You can “teach” the one-touch keys to carry out any of the following operations:

#### **Communications functions:**

- Delayed transmission (explained on page 3.11)
- Broadcasting (page 3.9)
- Regular polling (pages 3.15–3.16)
- F-Code transmission (page 3.36)
- F-Code polling (page 3.37)
- Batch transmission (pages 3.12–3.14)

To “teach” these keys, you tell the machine four simple things:

- **How** — The key you're programming
- **Who** — The number(s) the machine should dial
- **What** — The operation it should perform
- **When** — The date(s) and time(s) when you want it to perform the operation

#### **Printouts:**

- Function list (page 1.13)
- User settings list (page 4.10)
- Activity journal (page 3.22)
- Delayed commands list (page 2.7)
- One-touch list (page 3.3)
- Speed-dial list (page 3.5)
- Programmable one-touch list (page 3.45)
- Call group directory (page 3.7)
- Blocked numbers list (page 3.51)
- Sample cover page (page 3.24)
- Department time list (page 3.53)
- List of F-Code boxes (page 3.32)
- List of documents stored in F-Code boxes (page 3.32)
- Batch box list (page 3.13)
- List of stored batch documents (page 3.13)

- Macros list (page 3.21)

#### **Document storage:**

- Regular polling documents (page 3.15)
- F-Code polling documents (pages 3.32–3.34)

### Programming a delayed transmission

To program a delayed transmission into a programmable one-touch key:

- 1 Press **MENU**, **3**, **4**, **0**, **1**, **ENTER**. The LCD shows the first empty programmable one-touch number available:

```
01. Set P One-Touch
Select P One-Touch (57-60)
P1b57:Not Stored
```

- 2 Select the programmable one-touch key in which you want to program or change.

**Note:** You can select the programmable one-touch key by pressing that key on the control panel.

**Note:** If you're changing a previously stored command: If your previous command for this key was for a delayed operation, and you want to keep this key programmed for a delayed operation, use these instructions to make changes. But if you want to assign this key to a completely different operation, for example, a document storage operation, then you must first erase the stored command before programming the new one.

- 3 Press **ENTER**. The LCD asks which operation you want to program into the programmable one-touch:

```
01. Set P One-Touch
Communication
List Print
Store Document
```

**Note:** If changing a previously stored command, skip to step 7.

- 4 Using the cursor key, select “**Communication**” and press **ENTER**. The LCD shows:

```
P1b57:Not Stored
Enter Fax Number
-
```

- 5** Use the numeric keypad to enter the number *exactly* as your machine should dial it, including whatever codes your phone system requires. The number can be up to 40 characters in length:

Your display can show only 30 characters at a time. To view characters beyond those 30, press ◀ to scroll to the left or ▶ to scroll to the right.

- 6** Press **ENTER**. The LCD now asks which operation you want to program into the programmable one-touch:

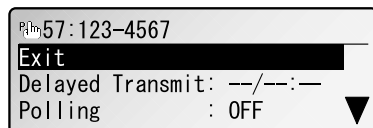

- 7** Select **“Delayed Transmit”** and press **ENTER**. The LCD shows:

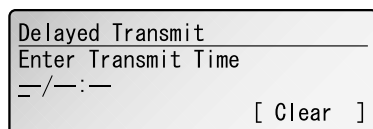

- 8** Tell your fax to carry out this delayed command one of these ways:

- Option 1:** Perform the command *once* at a certain time on a certain day of the month. (For example, “Do this at 5:05 PM on the 30th.”) To select this option, use the numeric keypad to enter the date and time when the fax should perform the command:

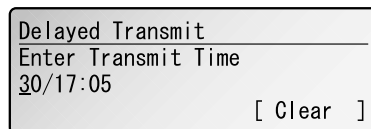

- Option 2:** Perform the command at a certain time *each day you press the key*. (For example, “Do this at 5:05 PM today.”) To select this option, use the numeric keypad to enter **0, 0** and then the time the fax should perform the command:

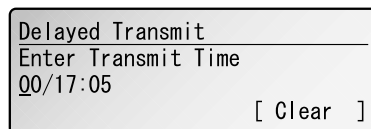

- 9** Press **ENTER**.

- 10** Select **“Exit”** and press **ENTER**. The LCD shows:

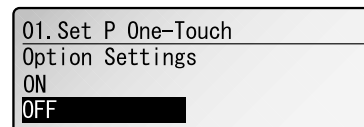

The LCD asks if you want to make *option settings* which includes; resolution, contrast, memory transmission, report, cover page and Fax & Copy. If you want to make any of these settings, select *ON* using the cursor key.

- 11** Press **ENTER**.  
If you select *ON*, proceed to step 12.  
If you select *OFF*, skip to step 16.

- 12** The LCD shows:

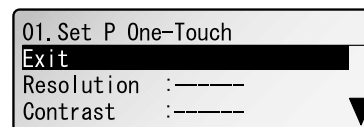

- 13** Using the cursor key, select the setting you want to specify for this programmable one-touch number. Then press **ENTER**.

- 14** Using the cursor key, select the mode you want. Then press **ENTER**.  
If you want to make another setting, repeat step 13 and 14.

**Note:** Choose “----” if you do not want to specify for this programmable one-touch key.

- 15** Select **“Exit”** and press **ENTER**.

- 16** Press **STOP** to return your machine to standby mode.

## Programming a broadcast

Programming a broadcast is very similar to programming a delayed transmission. But instead of sending to just one phone number, you set up multiple numbers for the transmission.

To program a broadcast into a programmable one-touch key:

- 1 Press **MENU, 3, 4, 0, 1, ENTER**. The LCD shows the first empty programmable one-touch number available:

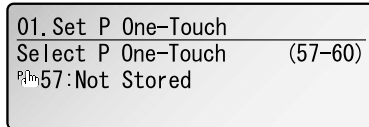

- 2 Select the programmable one-touch key in which you want to program or change.

**Note:** You can select the programmable one-touch key by pressing that key on the control panel.

**Note:** If you're changing a previously stored command: If your previous command for this key was for a broadcast operation, and you want to keep this key programmed for a broadcast operation, use these instructions to make changes. But if you want to assign this key to a completely different operation, for example, a document storage operation, then you must first erase the stored command before programming the new one.

- 3 Press **ENTER**. The LCD asks which operation you want to program into the programmable one-touch:

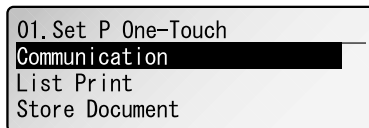

**Note:** If changing a previously stored command, skip to step 7.

- 4 Using the cursor key, select **“Communication”** and press **ENTER**. The LCD shows:

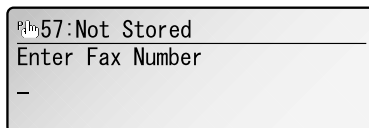

- 5 Use the numeric keypad to enter up to 330 fax numbers — you can use any combination of call groups, one-touch keys, speed-dial numbers and manually-dialed numbers.

To enter a *speed-dial number*, press **SPEED DIAL/GROUP** and the number's three-digit identifier.

To enter a *call group*, press **SPEED DIAL/GROUP** *twice* and the group's identifier number.

To add more fax numbers, press **BROADCAST**. Then enter the next number.

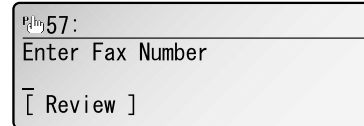

**Note:** If you want to review the numbers you entered, press **[Review]**.

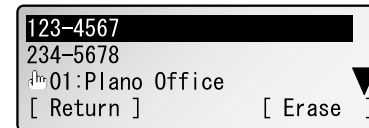

When you finish to review, press **[Return]** to return to the previous display.

- 6 When you enter all numbers you want, press **ENTER**. The LCD shows:

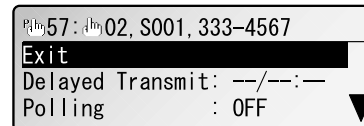

- 7 If you want the polling to begin *immediately* every time you press the key, proceed to step 8.

If you want to *delay* the polling, follow steps 7–9 on page 3.39.

- 8 Select **“Exit”** and press **ENTER**. The LCD shows:

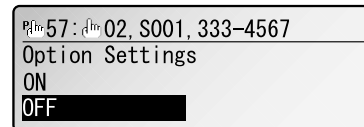

The LCD asks if you want to make *option settings* which includes; resolution, contrast, memory transmission, report, cover page and Fax & Copy. If you want to make any of these settings, select **ON** using the cursor key.

- 9 Press **ENTER**.  
If you select *ON*, proceed to step 10.  
If you select *OFF*, skip to step 13.
- 10 Using the cursor key, select the setting you want to specify for this programmable one-touch number. Then press **ENTER**.
- 11 Using the cursor key, select the mode you want. Then press **ENTER**.  
If you want to make another setting, repeat step 11 and 12.  
**Note:** Choose “----” if you do not want to specify for this programmable one-touch key.
- 12 Select “**Exit**” and press **ENTER**.
- 13 Press **STOP** to return your machine to standby mode.

## Programming regular polling

To program a regular polling operation into a programmable one-touch key:

- 1 Follow steps 1–6 on pages 3.38–3.39.
- 2 Select “**Polling**” and press **ENTER**. The LCD shows:
 

The LCD display shows the word "Polling" at the top. Below it, there are two options: "ON" and "OFF". The "OFF" option is currently selected, indicated by a black bar behind the text.
- 3 Select *ON* using the cursor key. Then press **ENTER**.
- 4 If you want the polling to begin *immediately* every time you press the key, proceed to step 5.  
If you want to *delay* the polling, follow steps 7–9 on page 3.39.
- 5 If you want to make additional settings for this programmable one-touch number, select it now. (Regarding the operation for programming it, see each page.)  
Otherwise, proceed to step 6.
- 6 Select “**Exit**” and press **ENTER**.
- 7 Press **STOP** to return your machine to standby mode.

## Programming an F-Code transmission

For this operation to work, two things must be true:

- You must know how the remote fax is using each F-Code box to which you’re transmitting — for example, as a security box or a relay box. Different fax manufacturers may use slightly different terms, but the concepts are the same.
- You must know the remote fax’s ITU-T sub-address and password for each box to which you want to transmit.

To program an F-Code transmission into a programmable one-touch key:

- 1 Follow steps 1–6 on pages 3.39.
- 2 Select “**F-Code Transmit**” and press **ENTER**. The LCD shows:

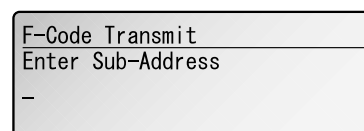

- 3 Use the numeric keypad to enter the ITU-T sub-address for the box to which you want to send the document.
- 4 Press **ENTER**. The LCD shows:

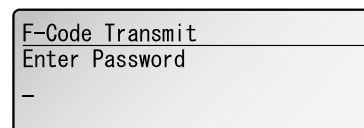

- Note:** If there isn’t a password for this box, press **ENTER**, then skip to step 6.
- 5 Use the numeric keypad to enter the appropriate ITU-T password for the box. Then press **ENTER**.
- 6 If you want the transmission to begin *immediately* every time you press the key, proceed to step 7.  
If you want to *delay* the transmission, follow steps 7–9 on page 3.39.
- 7 Select “**Exit**” and press **ENTER**.  
The LCD asks if you want to make *option settings* which includes; resolution, contrast, memory transmission, report, cover page and Fax & Copy. If you want to make any of these settings, select *ON* using the cursor key.
- 8 Press **ENTER**.  
If you select *ON*, proceed to step 9.  
If you select *OFF*, skip to step 12.
- 9 Using the cursor key, select the setting you want to specify for this programmable one-touch number. Then press **ENTER**.



- 10** Using the cursor key, select the mode you want. Then press **ENTER**.  
If you want to make another setting, repeat step 9 and 10.  
**Note:** Choose “-----” if you do not want to specify for this programmable one-touch key.
- 11** Select “**Exit**” and press **ENTER**.
- 12** Press **STOP** to return your machine to standby mode.

### Programming F-Code polling

For this operation to work, two things must be true:

- The document which you’re polling must exist in the remote fax’s F-Code box (ITU-T standard sub-addressing/password box).
- You must know the remote fax’s ITU-T sub-address and password (if any) for each box you want to poll.

To program an F-Code polling operating into a programmable one-touch key:

- 1** Follow steps 1–6 on pages 3.39.
- 2** Select “**F-Code Polling**” and press **ENTER**. The LCD shows:

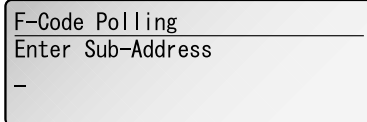

- 3** Use the numeric keypad to enter the ITU-T sub-address for the box to which you want to send the document.
- 4** Press **ENTER**. The LCD shows:

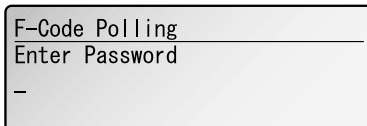

**Note:** If there isn’t a password for this box, press **ENTER**, then skip to step 6.

- 5** Use the numeric keypad to enter the appropriate ITU-T password for the box. Then press **ENTER**.
- 6** If you want the polling to begin *immediately* every time you press the key, proceed to step 7.  
If you want to *delay* the polling, follow steps 7–9 on page 3.43.

- 7** Select “**Exit**” and press **ENTER**.  
The LCD asks if you want to make *option settings* which includes; resolution, contrast, memory transmission, report, cover page and Fax & Copy. If you want to make any of these settings, select *ON* using the cursor key.
- 8** Press **ENTER**.  
If you select *ON*, proceed to step 9.  
If you select *OFF*, skip to step 12.
- 9** Using the cursor key, select the setting you want to specify for this programmable one-touch number. Then press **ENTER**.
- 10** Using the cursor key, select the mode you want. Then press **ENTER**.  
If you want to make another setting, repeat step 9 and 10.  
**Note:** Choose “-----” if you do not want to specify for this programmable one-touch key.
- 11** Select “**Exit**” and press **ENTER**.
- 12** Press **STOP** to return your machine to standby mode.

## Programming a batch transmission

**Note:** For this operation to work, one thing must be true:

- The batch box you're using must exist on your fax machine.

To program a batch transmission into a programmable one-touch key:

- 1 Follow steps 1–4 on page 3.38.

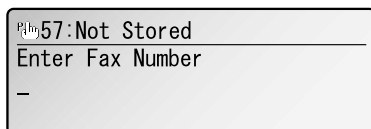

- 2 Press **ENTER** without entering any characters.

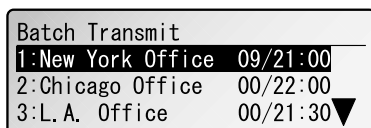

- 3 Select the batch box you want to assign to this one-touch key. Then press **ENTER**. The LCD will show:

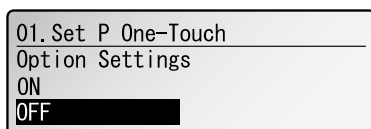

The LCD asks if you want to make *option settings* which includes; resolution, contrast and Fax & Copy. If you want to make any of these settings, select *ON* using the cursor key.

- 4 Press **ENTER**.  
If you select *ON*, proceed to step 5.  
If you select *OFF*, skip to step 8.
- 5 Using the cursor key, select the setting you want to specify for this programmable one-touch number. Then press **ENTER**.
- 6 Using the cursor key, select the mode you want. Then press **ENTER**.  
If you want to make another setting, repeat step 5 and 6.  
**Note:** Choose “-----” if you do not want to specify for this programmable one-touch key.
- 7 Select “**Exit**” and press **ENTER**.
- 9 Press **STOP** to return your machine to standby mode.

## Programming printouts

To program a programmable one-touch key to print a list:

- 1 Press **MENU**, **3**, **4**, **0**, **1**, **ENTER**. The LCD shows the first empty programmable one-touch number available:

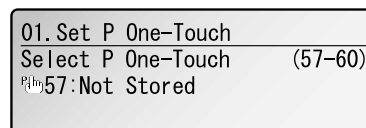

- 2 Select the programmable one-touch key in which you want to program or change.

**Note:** You can select the programmable one-touch key by pressing that key on the control panel.

**Note:** If you're changing a previously stored command: If your previous command for this key was for a printout operation, and you want to keep this key programmed for a printout operation, use these instructions to make changes. But if you want to assign this key to a completely different operation, for example, a batch transmission, then you must first erase the stored command before programming the new one.

- 3 Press **ENTER**. The LCD asks which operation you want to program into the programmable one-touch:

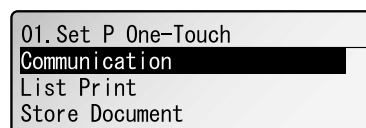

- 4 Using the cursor key, select “**List Print**” and press **ENTER**. The LCD shows:

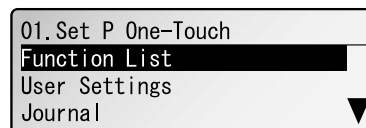

- 5 Using the cursor key, select the list you want. Then press **ENTER**.
- 6 Press **STOP** to return your machine to standby mode.

## Programming a document storage operation

If you want to program a programmable one-touch key to store an F-Code polling document, two things must be true:

- The F-Code bulletin box must exist on your fax machine.
- You must know the F-Code bulletin box's two-digit number (01-50) and name.

To program your programmable one-touch to store a regular polling document or F-Code polling document:

- 1 Press **MENU, 3, 4, 0, 1, ENTER**. The LCD shows the first empty programmable one-touch number available:

```
01. Set P One-Touch
Select P One-Touch (57-60)
F-Code 57: Not Stored
```

- 2 Select the programmable one-touch key in which you want to program or change.

**Note:** You can select the programmable one-touch key by pressing that key on the control panel.

**Note:** If you're changing a previously stored command: If your previous command for this key was for a document storage operation, and you want to keep this key programmed for a document storage operation, use these instructions to make changes. But if you want to assign this key to a completely different operation, for example, a batch transmission, then you must first erase the stored command before programming the new one.

- 3 Press **ENTER**. The LCD asks which operation you want to program into the programmable one-touch:

```
01. Set P One-Touch
Communication
List Print
Store Document
```

**Note:** If changing a previously stored command, skip to step 7.

- 4 Using the cursor key, select **"Store Document"** and press **ENTER**. The LCD shows:

```
01. Set P One-Touch
Polling Document
F-Code Document
```

- 5 Using the cursor key, select the document you want to store.

- 6 Press **ENTER**.  
If you select the *"Polling Document"* operation, skip to step 11.  
If you select the *"F-Code Document"* operation, go on to step 7.

- 7 The LCD asks which F-Code bulletin box you want to use.

```
01. Set P One-Touch
Enter Box Number (01-50) : _
01: Plano Office
```

- 8 Use the numeric keypad to enter the two-digit identifier number (01-50) of the F-Code box in which you want to store the document.

- 9 Press **ENTER**. The LCD shows:

```
01. Set P One-Touch
Overwrite Document
ON
OFF
```

- On: When your machine stores a new document into this box, it will overwrite documents stored in it.
- Off: When your machine stores a new document into this box, it won't erase (overwrite) any documents stored in it. Your machine can store up to 30 documents in each box (each document can include one or more pages).

- 10 Using the cursor key, select the mode you want. Then press **ENTER**.

- 11 The LCD shows:

```
01. Set P One-Touch
Option Settings
ON
OFF
```

The LCD asks if you want to make *option settings* which includes; resolution, contrast and Fax & Copy. If you want to make any of these settings, select *ON* using the cursor key.

- 12 Press **ENTER**.  
If you select *ON*, proceed to step 13.  
If you select *OFF*, skip to step 17.

**13** The LCD will show:

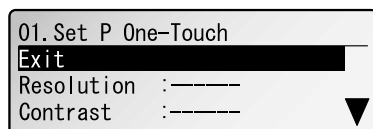

**14** Using the cursor key, select the setting you want to specify for this programmable one-touch number. Then press **ENTER**.

**15** Using the cursor key, select the mode you want. Then press **ENTER**.  
 If you want to make another setting, repeat step 14 and 15.

**Note:** Choose "-----" if you do not want to specify for this programmable one-touch key.

**16** Select "**Exit**" and press **ENTER**.

**17** Press **STOP** to return your machine to standby mode.

## Fax dialing with programmable one-touch

To dial a fax call using a programmable one-touch number:

- 1** Set your document in the ADF.
- 2** Make any necessary adjustments as usual.
- 3** Press the programmable one-touch key in which you've stored the fax communication command.

Your fax will perform the operation now, or at whatever time you programmed.

**Note:** To review the details of each operation, review the instructions for that operation. See page 3.38 for a list of each operation and where to find it.

If you programmed this key to delay its operation, the LCD shows:

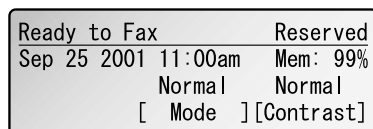

If you programmed this key to perform the operation immediately after you press it, the LCD shows the number:

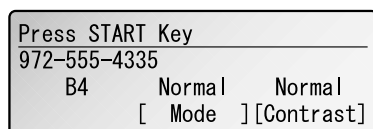

## Printing a list of your programmable one-touch keys

Your fax machine can print a list of the commands you've stored in your programmable one-touch keys.

The list includes:

- (1) each key's one-touch number
- (2) the fax/telephone number
- (3) when the command should start
- (4) which command you've selected
- (5) if applicable, the selected call group(s) or F-Code box(es) you've stored in the key
- (6) the individual settings for each key

To print a list of programmable one-touch keys, press **MENU, 5, 1, 1, 1, ENTER**.

## Erasing a programmable one-touch key

**1** Press **MENU, 3, 4, 0, 2**. The LCD shows:

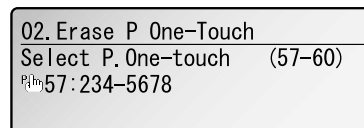

**2** Select the programmable one-touch key you want to erase.

**Note:** You can select the programmable one-touch key by pressing that key on the control panel.

**3** Press **ENTER**. The LCD shows:

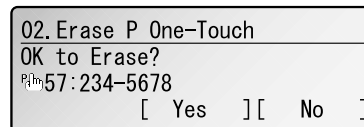

**Important:** If you want to quit without erasing the one-touch number you've selected, press **[No]**. The fax will return to step 2.

**4** Press **[Yes]** to erase the number.

To erase another program one-touch number, repeat steps 2-4. Or press **STOP** to return to standby mode.

# Security features

Your machine has a number of security features to keep your private fax documents private, avoid unwanted outside communication and even protect against unauthorized use of your machine.

These security features include:

(1) Security reception, (2) PIN mask, (3) Block junk fax, and (4) Department codes.

## The passcode

Your machine has a *passcode protection* system which must be turned on in order to use the security features listed below:

- Security reception
- PIN mask
- Department code protection

To set your machine's passcode:

- 1 Decide on the four-digit passcode (0001–9999) you want to use. Write it down, and put it in a safe place.

**Important:** Do not use 0000. This turns off passcode protection.

- 2 Press **MENU, 2, 1, 0, 2, ENTER**.  
If you are *creating* a passcode, skip to step 5.  
If you are *changing* an *existing* passcode, proceed to step 3.

- 3 The LCD shows:

```
02. Protect Passcode
Old Passcode (0000-9999)
-
```

- 4 Use the numeric keypad to enter the existing passcode. Then press **ENTER**.

- 5 The LCD shows:

```
02. Protect Passcode
New Passcode (0000-9999)
-
0000 for Turning off Passcode
```

- 6 Enter the new four-digit passcode. Then press **ENTER** to save the passcode.

**Note:** Any time you want to turn off the passcode, change the passcode back to 0000 by repeating steps 2–6 and entering 0000 in step 6.

## Security reception

*Security reception* tells your machine to keep *all* received faxes in memory (but not print them). Then you can print them out later, at your convenience. For example, you could use this if you're concerned about workers reading documents intended for your eyes only.

**Important:** For this feature to work, you must have activated the *passcode protection* as described on left column. You must also *know* the passcode.

**Note:** In the following instructions, your machine's LCD shortens the word *Transmission* to *Tx* and the word *Receive* to *Rx*.

### Activating security reception

- 1 Press **MENU, 2, 2, 1, 1, ENTER**. The LCD shows:

```
11. Security Rx
Enter Passcode (0000-9999)
-
```

- 2 Use the numeric keypad to enter the protection passcode.

- 3 Press **ENTER**. The LCD shows:

```
11. Security Rx
ON
OFF
```

- 4** Using the cursor key, select the mode you want. Then press **ENTER**. The LCD shows the machine's current clock setting:

```
11. Security Rx
Enter Start Time
13:30
```

- 5** If you want security reception to begin *now* (and at this same time every day), skip to step 7. Otherwise, go on to step 6.
- 6** Use the numeric keypad to enter the time (use a 24-hour format) when security reception should begin every day. "Type over" the numbers displayed. To change a digit, press **◀** to move to the left, or **▶** to move right. Then enter the correct digit.
- 7** Press **ENTER** to save the setting.

**Note:** After setting for activating the security reception, you can assign the security reception to the Soft key (see page 3.17) to turn it on and off. Turning on the security reception by pressing a Soft key is not effected the time setting you entered at step 6. It begins the security reception immediately.

To turn the security reception on by pressing a soft key:

- 1** Program a Soft key for security reception. (See page 3.17.)
- 2** Press a Soft key that is assigned for security reception.

```
Security Rx
Enter Passcode (0000-9999)
-
```

- 3** Enter the protection passcode and then press **ENTER**.

**Note:** To turn the security reception off, see "*Printing from security reception / Turning off security reception,*" next column.

## Printing from security reception / Turning off security reception

When security reception is on, an incoming fax goes directly into your machine's memory and the **MEMORY RECEIVE** light comes on. But the incoming fax message is not printed.

To retrieve the faxes received during this security reception (and to return your machine to normal reception until the next time):

- 1** Press **MENU, 4, 3, 0, 4, ENTER**. If you using the Soft key, press the Soft key instead of this operation. In which way, the LCD shows:

```
Security Rx Document
Enter Passcode (0000-9999)
-
Security Rx will be OFF
```

- 2** Use the numeric keypad to enter the passcode.
- 3** Press **ENTER**.
  - If you've entered the correct passcode, your fax machine will print all documents in its memory and then erase them. Then it will turn security reception off until the next time you've scheduled security reception or the Soft key which programmed security reception is pressed. If you using the Soft key, the LED light of the Soft key will be off.
  - If you've entered an incorrect passcode, your fax machine will refuse to print, and security reception remains on.

## Masking the PIN

To prevent unauthorized long-distance calls, some office telephone systems require you to enter a *personal identification number (PIN)* whenever you dial long distance.

Your fax's *PIN mask feature* helps you keep that PIN number private. With the PIN mask activated, you can dial a fax number plus a PIN, but the PIN will not appear in a journal, error message printout, delayed command list or a TCR. The PIN may be up to eight characters in length. It also can include the \* or # symbols, and it can be entered from the numeric keypad.

There are three possible settings for the PIN mask:

- *Off* — Turns off the PIN mask feature. Any PIN you enter will appear on any display or printout which shows the number you dial.
- *Mode 1* — Each *remote fax unit* has a departmental PIN access code.
- *Mode 2* — Each *fax user* has a departmental PIN access code.

**Note:** If you select Mode 1 and you will use a one-touch or speed-dial number, you must store the remote unit's PIN access code within that number. However, if you select Mode 2, this isn't necessary. (See "Autodialing while using the PIN mask," next column for further details.)

**Note:** If you select either Mode 1 or Mode 2 and will be using batch transmission (see pages 3.12–3.14), you must store the PIN access code for the remote unit within the appropriate batch box.

**Important:** For this feature to work, you must have activated the *passcode protection* as described on page 3.46. You must also *know* the passcode.

### Activating the PIN mask

**Important:** For this feature to work, you must have activated the *passcode protection* as described on page 3.46. You must also *know* the passcode.

- 1 Press **MENU, 2, 2, 1, 4, ENTER**. The LCD shows:

```

14. PIN Mode
Enter Passcode (0000-9999)
_
  
```

- 2 Use the numeric keypad to enter the four-digit passcode.

**Note:** If you enter an invalid passcode, the machine's security feature rejects the attempt and returns to standby mode.

- 3 Press **ENTER**. The LCD shows:

```

14. PIN Mode
OFF
Mode1
Mode2
  
```

- 4 Using the cursor key, select the mode you want.

- 5 Press **ENTER**.

### Autodialing while using the PIN mask

**Note:** The following instructions presume you understand how to set and use your machine's autodialer. If you need to review, see pages 3.1–3.6.

*If you chose "Mode 1" — the PIN goes in*

In Mode 1, before autodialing a number for the first time, you must add the PIN to the stored one-touch key or speed-dial number. Here's how:

- 1 Begin by creating or changing an entry in the autodialer. See pages 3.1–3.6 if necessary. While you're setting this up, the machine asks you to enter the PIN.

```

001:234-5678
Exit
Location:
PIN:
  
```

- 2 Select "**PIN :**" and then press **ENTER**. The LCD shows:

```

001:234-5678
Enter PIN Number
_
  
```

- 3 Use the numeric keypad to enter the desired PIN, up to eight characters in length.

**5** Press **ENTER** to save the PIN.

**Note:** If you press **ENTER** without entering the PIN, the fax machine beeps, indicates “Invalid Number” on the LCD and then returns to step 4.

Now you may autodial the number as usual.

**Important:** While in PIN Mode 1, *any* autodialer numbers you use must include the PIN. This also applies to autodialer numbers used with batch transmission (see page 3.12) or programmable one-touch keys (see pages 3.38–3.45).

**Note:** If you select either Mode 1 or Mode 2 and will be using batch transmission, you must store the PIN access code for the remote unit within the appropriate batch box.

*If you chose “Mode 2” — as you autodial, load the code*

In this mode, you *don't* have to add the PIN to the autodialer setting. Instead, you enter the PIN manually each time you autodial:

**1** Dial the number as you normally would, using the autodialer. Here, we've pushed one-touch key **01**. The machine now asks for the PIN.

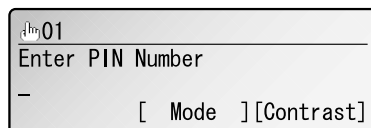

**2** Use the numeric keypad to enter the PIN.

**3** Press **START**. Your machine dials the number.

**Note:** If you select either Mode 1 or Mode 2 and will be using batch transmission (see page 3.12), you must store the PIN access code for the remote unit within the appropriate batch box.

## Dialing from the numeric keypad while using the PIN mask

*If you've specified Mode 1 — use “star” power*

**1** Enter the phone number, then press the \* (“star”) key and enter the PIN. *The PIN always goes last.* For example, to dial 19725550911 with a PIN of “123456”, enter 19725550911\*123456:

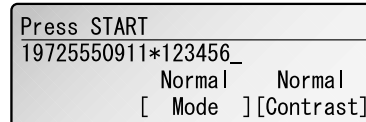

**2** Press **START**. The PIN disappears from the display, and your machine dials the desired phone number.

*If you've specified Mode 2 — the machine guides you*

**1** Enter the phone number as usual.

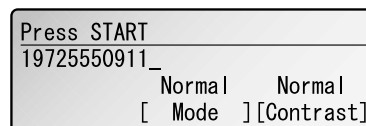

**2** Press **START**. The LCD shows:

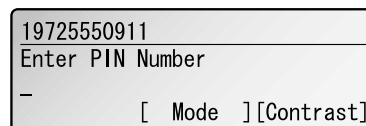

**3** Use the numeric keypad to enter the PIN.

**4** Press **START**. Your machine dials the number.



## Performing batch transmission while using the PIN mask

**Note:** The following instructions presume you are familiar with how to set and use both your machine's autodialer and its batch transmission feature. If you need to review, see pages 3.1–3.5 for more on the autodialer and/or page 3.12 for more on batch transmission.

*If you've specified Mode 1 or Mode 2*

**Important:** Any autodialer number you use with batch transmission *must* include the PIN. (To review how to include this information in an autodialer number, review the Mode 1 instructions under “Autodialing while using the PIN mask,” page 3.48.)

Before sending a batch transmission the first time, you must store the PIN within its batch box. Here's how:

- 1 Follow the steps for creating or modifying a batch box (pages 3.12–3.13). The LCD asks for the fax number (here, we're working with batch box 1).

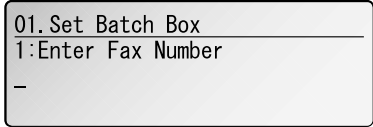

```
01. Set Batch Box
1: Enter Fax Number
_
```

- 2 Enter an autodialer number, or use the numeric keypad to enter the fax number, to which the batch transmission should go.

**Important:** If you're entering a number from the numeric keypad, enter the fax number, followed by the \* (“star”) key and then the PIN.

- 3 Press **ENTER** to save the setting.

**Note:** If you press **ENTER** without entering the PIN, the fax machine beeps, indicates “PIN is not Stored” on the LCD and then returns you to step 2.

- 4 Continue with the steps for creating or modifying a batch box (pages 3.12–3.13).

Now you can perform batch transmission to this box while the PIN mask is activated.

## Setting Block Junk Fax

Your fax machine's *Block Junk Fax* feature lets you bar the gates against unauthorized incoming faxes (“junk fax”). But before you block junk fax, first understand *how* this feature works, to determine if it's right for you. There are four possible settings for Block Junk Fax:

- *Off* — The feature isn't activated.
- *Mode1* — Your fax machine checks whether the last four digits of any phone number in your autodialer matches the last four digits of the remote fax's subscriber ID (the phone number part of the TTI). If it doesn't find a match, your machine disconnects the call.
- *Mode2* — This mode rejects any call from a number whose last eight digits match any number in the *blocked numbers list* (explained later). Your machine can hold up to 50 blocked numbers.
- *Mode3* — This rejects numbers that are *not* in the autodialer and also rejects numbers that *are* in the blocked numbers list. This lets you keep a number on your autodialer for transmission to it, while still blocking its incoming calls by putting it in the blocked numbers list.

But before you activate the Block Junk Fax feature, please consider:

- *Not all fax machine owners enter their phone numbers in their Subscriber IDs.* — With Block Junk Fax activated, your machine would reject faxes from these machines.
- *Access codes can cause confusion.* — If an autodialer entry ends with extra codes, such as long-distance codes, Block Junk Fax will block out calls from those faxes.

To set the mode for Block Junk Fax:

- 1 Press **MENU**, **2**, **2**, **1**, **0**, **ENTER**. The LCD shows:

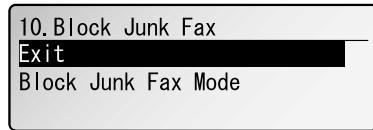

```
10. Block Junk Fax
Exit
Block Junk Fax Mode
```

- 2 Select “**Block Junk Fax Mode**” and press **ENTER**. The LCD shows:

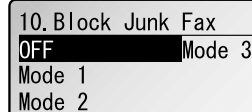

```
10. Block Junk Fax
OFF Mode 3
Mode 1
Mode 2
```

- 3 Using the cursor key, select the mode you want. Then press **ENTER**.

- 4 If you selected *OFF* or *Mode1*, skip to step 9. If you selected either *Mode2* or *Mode3*, go on to step 5.

- 5 The LCD shows:

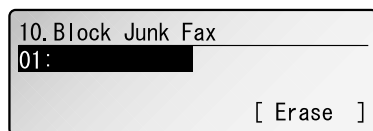

- 6 If you want to modify an existing entry in the blocked numbers list, select the number you want to modify using the cursor key.

... or ...

If you want to enter a new number in an already-started blocked numbers list, select an empty position in the list.

Then press **ENTER** to enter or modify the blocked number.

**Note:** To *clear* a number from the list, see “Clearing a number from the blocked numbers list,” next column.

- 7 Use the numeric keypad to enter *the last eight characters* of a fax number you want to block. For example, if you want to block a fax from someone with a Subscriber ID of 972-555-3038, you should enter **5, 5, 5, PAUSE/DIAL OPT., 3, 0, 3, 8:**

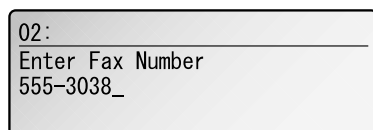

To change a specific digit, press **◀** to move left or **▶** to move right until the cursor is under the digit, then use the numeric keypad to enter the correct number.

- 8 Press **ENTER** to save the setting. The LCD shows the next “slot” in the blocked numbers list.

If you *do not* want to enter or change a number for this slot, go on to step 9.

If you *do* want to enter or change a number for this slot, repeat steps 6–8.

- 9 Press **STOP** to return your machine to standby mode.

## Clearing a number from the blocked numbers list

To *clear* a number from the list:

- 1 Press **MENU, 2, 2, 1, 0, ENTER**. The LCD shows:

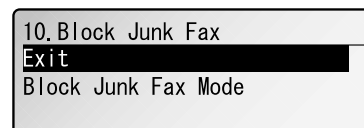

- 2 Select “**Block Junk Fax Mode**” and press **ENTER**. The LCD shows:

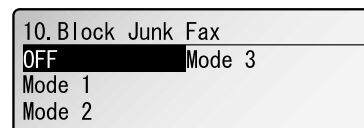

- 3 Select *Mode 2* or *Mode 3*. The LCD shows:

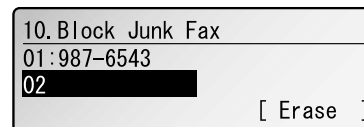

- 4 Using the cursor key, select the number you want to clear.

- 5 Press **[Erase]** to clear the number. The LCD shows:

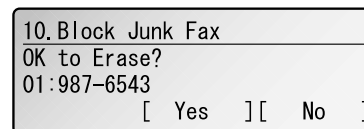

**Important:** If you want to quit without erasing the number you’ve selected, press **[No]**. The fax will return to step 4.

- 6 Press **[Yes]** to clear the number.  
To clear another number from the blocked numbers list, repeat steps 4–6.  
Otherwise, go on to step 7.

- 7 Press **STOP** to return your machine to standby mode.

## Printing a list of the blocked numbers

Forgot which number is stored in the blocked number list? Just print a list of the blocked numbers.

To print a list of the blocked numbers, press **MENU, 5, 1, 0, 8, ENTER**.

## Using department codes

You can keep track of how your machine is used through its *department code* feature. When the department code setting is activated, the machine reminds each user to enter the department code before sending or polling a document. The Activity Journal then keeps track of fax transactions by department.

After you turn on this setting, assign specific code numbers to your office's fax users and tell them to enter these department codes before sending faxes.

**Note:** Please note that using this setting may block access to the fax machine.

### Entering a department code

Your machine can hold up to 100 separate department codes.

To enter a department code:

- 1 Press **MENU, 3, 3, 0, 2, ENTER**. The LCD shows:

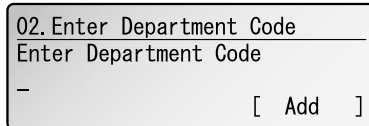

**Note:** If department code operation is *protected* (see page 3.53), the fax beeps briefly and then returns to standby mode. You will have to turn off the protection first, then repeat this step.

- 2 Use the numeric keypad to enter the four-digit department code, 0000-9999. To enter more codes, press [ **Add** ]. A comma will be inserted.

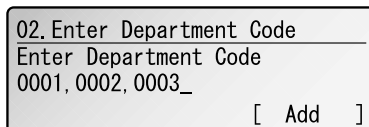

**Note:** If you want to clear an existing department code, move the cursor and press **CANCEL** to erase it.

- 3 When you finished entering all department codes you want, press **ENTER**. Press **STOP** to return to standby mode.

### Clearing a department code

- 1 Press **MENU, 3, 3, 0, 2, ENTER**. The LCD shows:

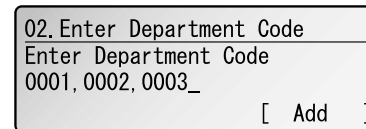

**Note:** If department code operation is *protected* (see page 3.53), the fax beeps briefly and then returns to standby mode. You will have to turn off the protection first, then repeat this step.

- 2 Move the cursor and press **CANCEL** to erase it.
- 3 When you finished clearing, press **ENTER**. Press **STOP** to return to standby mode.

### Turning the department code setting on and off

- 1 Press **MENU, 3, 3, 0, 3, ENTER**. The LCD shows:

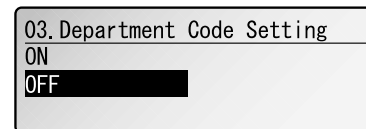

**Note:** If department code operation is *protected* (see next page), the fax beeps briefly and then returns to standby mode. You will have to turn off the protection first, then repeat this step.

**Important:** To turn the department code setting on, at least one department code must be existed in your machine.

- 2 Using the cursor key, select the mode you want.
- 3 Press **ENTER**.

## Turning department code protection on and off

**Important:** This feature will work only if you've activated the *passcode protection* (see page 3.46).

- 1 Press **MENU, 3, 3, 0, 1, ENTER**. The LCD shows:

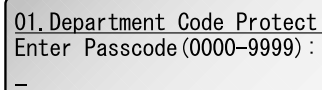

```
01. Department Code Protect
Enter Passcode (0000-9999) :
_
```

- 2 Use the numeric keypad to enter the four-digit passcode.  
To change one digit, press ◀ to move left or ▶ to move right until the cursor is under the digit, then use the numeric keypad to enter the correct number.

- 3 Press **ENTER**. The LCD shows:

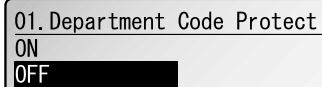

```
01. Department Code Protect
ON
OFF
```

- 4 Using the cursor key, select the mode you want.
- 5 Press **ENTER** to save the setting.

## Sending a fax using a department code

For this operation to work, two things must be true:

- The four-digit department code must exist on your fax machine.
- You must know the department code.

- 1 Insert the document.
- 2 Adjust resolution and contrast if necessary.
- 3 Enter the fax number by either pressing a one-touch key, entering a speed-dial number or dialing from the numeric keypad.  
If you enter the fax number using a one-touch key, skip to step 5.  
Otherwise, go on to step 4.
- 4 Press **START**.

- 5 The LCD shows:

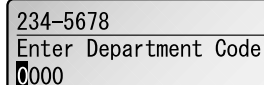

```
234-5678
Enter Department Code
0000
```

- 6 Use the numeric keypad to enter the appropriate four-digit department code.
- 7 Press **START** again.

## Printing the department time list

To print the list, press **MENU, 5, 1, 1, 0, ENTER**.

**Note:** If department code operation is *protected* (see left column), the fax beeps briefly and then returns to standby mode. You will have to turn off the protection first, then repeat the above.

The department time list includes the following information for each department code:

- *Time period* covered by the department time list
- Each *department code*
- *Total communication time* (in hours, minutes and seconds; *HH:MM:SS*) — Counts the communication time up to 999:59:59 (999 hours:59 minutes:59 seconds). If the fax exceeds the maximum time, it does not count further.
- *Total printed pages* — Counts the pages up to 65535 pages. If the fax exceeds the maximum number of pages, it counts the total pages from 0 (zero).

**Note:** If you want to clear the total counts of each department code, see “Clearing the department time list”, below.

## Clearing the department time list

To clear the current total counts of each department code:

Press **MENU, 3, 3, 0, 4, ENTER, ENTER**.

The total communication time and total printed pages for each department code are cleared. The department code will not be erased.

# Changing the default settings

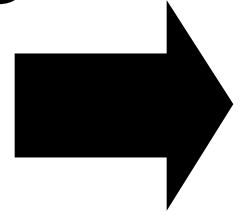

*This chapter describes how to change the settings of your machine.*

Settings for transmission .....	4.1
Settings for reception .....	4.3
Settings for dialing .....	4.5
Settings for copying .....	4.6
Settings for operation .....	4.8

# Settings for transmission

## Scan settings

**Default setting:** Primary resolution: Normal, Primary contrast: Normal, Scan width: B4

Three different settings tell your machine how to scan documents. The initial factory settings are probably right for most applications, so try using them before changing any of these settings:

- **Primary resolution mode** — Sets the resolution for your documents. Choose either normal, fine, superfine (“S-Fine” on the LCD) or grayscale mode (“Gray”).
- **Primary contrast mode** — Sets how light or dark you want faxed documents to be when they arrive at their destinations.
- **Scan width** — Sets the scan width for your documents. Choose either B4 or A4.

**Note:** These settings you choose effect your fax activity only.

To set these modes:

**1** Press MENU, 2, 2, 0, 1, ENTER. The LCD shows:

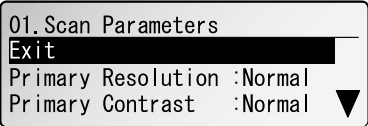

**2** To set the primary resolution mode, select “Primary Resolution” and then press ENTER. The LCD will show:

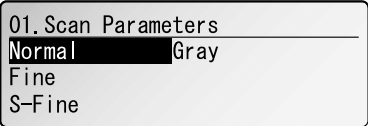

**3** Select resolution mode you want to set using the cursor key, then press ENTER.

**4** To set the primary contrast mode, select “Primary Contrast” and then press ENTER. The LCD will show:

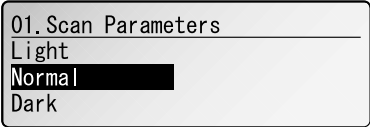

**5** Select contrast mode you want to set using the cursor key, then press ENTER.

**6** To set the primary scan width, select “Scan Width” and then press ENTER. The LCD will show:

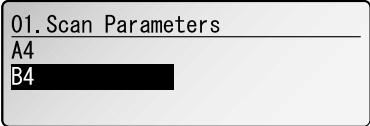

**7** Select scan width you want to set using the cursor key, then press ENTER.

**8** When you finished your choice, select “Exit” and then press ENTER to save the settings.

By following the steps above, you’ve set your defaults for scanning. Before sending documents, you can “override” these default scan settings for that transmission.

To override the default resolution and contrast settings before sending a document:

- Press [Mode] to change the resolution.
- Press [Contrast] to change the contrast.

Once your document is transmitted, your machine returns to its default settings.

## Setting ECM

**Default setting:** ON.

“Line noise,” or static on the line during a call, can easily disrupt the flow of data from one fax machine to another.

That’s why your fax machine gives you the option of using *Error Correction Mode (ECM)*. When two fax machines communicate while running in ECM, the sending machine automatically *checks* the data as it sends. If the receiving fax machine can’t verify the transmission, the first machine will re-send it as necessary.

**Note:** ECM gives you a better chance of transmitting a fax document over a bad phone line, but it could also slow down the transmission time. The worse a line is, the slower the transmission. That’s why the machine lets you turn ECM on or off as needed.

**Note:** Not all fax machines have ECM. If you’ve activated ECM and then transmit to a fax machine not currently using ECM, there will be no change in the fax transmission from a usual, non-ECM transmission.

- 1 Press **MENU, 2, 2, 0, 9, ENTER**. The LCD shows the current ECM setting:

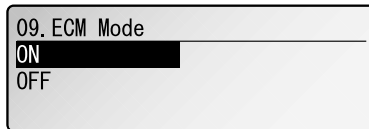

- 2 Using the cursor key, select the mode you want.  
Then press **ENTER** to save the setting.

---

## Memory transmission

**Default setting:** ON.

**Note:** When the machine’s memory is full, it can transmit only through the document feeder (real time transmission).

To change the default setting of memory transmission:

- 1 Press **MENU, 2, 2, 0, 6, ENTER**. The LCD shows:

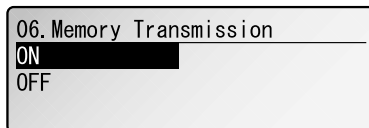

- 2 Using the cursor key, select the mode you want.

Then press **ENTER** to save the setting.

If the **MEMORY TRANSMIT** light glows, memory transmission is *on*.

If the **MEMORY TRANSMIT** light doesn’t glow, memory transmission is *off*.

---

## Quick Memory transmission

**Default setting:** ON.

**Important:** Your fax machine’s memory transmission feature must be turned on to use Quick Memory transmission (see left column).

To change the default setting of Quick Memory transmission:

- 1 Press **MENU, 2, 2, 0, 7, ENTER**. The LCD shows:

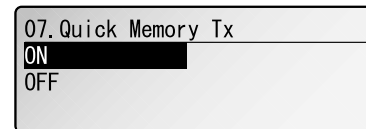

- 2 Using the cursor key, select the mode you want.  
Then press **ENTER** to save the setting.

---

## TTI transmission

**Default setting:** ON.

Every fax page you send arrives at the receiving machine with a single line of text at the very top of the page. This text lists a name, called the Transmit Terminal Identifier (TTI), and a fax number. You can set the machine to not send the TTI.

- 1 Press **MENU, 2, 2, 0, 8, ENTER**. The LCD shows:

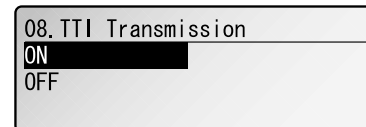

- 2 Using the cursor key, select the mode you want.  
Then press **ENTER** to save the setting.

# Settings for reception

## Print settings

You can set three parameters for printing received fax messages:

- Print reduction rate
- Reduction margin
- Paper save function

You set all three in the same procedure, discussed on next column. Following is a explanation for each:

### Print reduction rate

*Print reduction* lets you set the machine to reduce large incoming documents to a size that fits the paper in your machine. (This setting doesn't affect copies you may make with your machine.)

Below are the options for both the print reduction and copy reduction settings:

Setting	What it does
Auto	Automatically reduces printouts at variable rates down to a minimum of 50%. Tries to reduce printout to fit on one sheet of your selected paper size. If it can't, print the image at 100% size on two or more pages.
100%	Does not reduce document. (Due to the sender's TTI, this may print two pages when receiving a one-page fax document.)

### Reduction margin

Your machine's *reduction margin* is measured in millimeters (mm). We'll define *reduction margin* by explaining how it's used:

When a fax message enters your machine's electronic brain, the machine measures the message's length and compares it to (a) the length of your selected paper (not include the print margins) plus (b) the reduction margin you set. If the length of the incoming message is shorter than (a) and (b) put together, your machine prints the message on just one sheet.

If it's longer, your machine prints the message on more than one sheet.

**Note:** An *Auto* reduction setting and a reduction margin setting of 40mm will print most incoming faxes as single pages. Try this combination first and then, only if you have problems with it, select different settings.

## Half-page reception

*Half-page reception* can conserve paper if some of the faxes you receive are half-page, "memo-sized" messages. When activated, this feature tells the machine to combine two of these half-page receptions onto a single sheet. Half-page reception only combines half-page messages sent back-to-back *during the same transmission*. It won't combine two half-page faxes from separate transmissions.

### To adjust the print settings

**Default setting:** Rx reduction rate: Auto, Reduction margin: 40 mm, Half-page reception: OFF.

- 1 Press MENU, 2, 2, 0, 2, ENTER. The LCD shows:

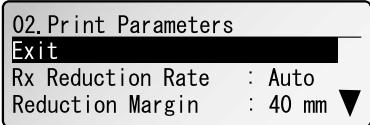

- 2 To set the reduction rate for fax reception, select "Rx Reduction Rate" using the cursor key and then press ENTER. The LCD will show:

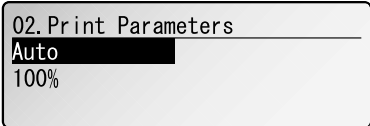

- 3 Select "Auto" or "100%" then press ENTER.

- 4 To set the reduction margin for fax reception, select "Reduction Margin" using the cursor key and then press ENTER. The LCD will show:

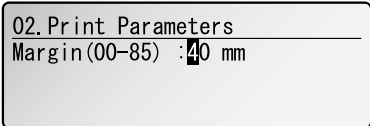

- 4 Use the numeric keypad to enter the reduction margin you want, from 00 to 85.

**Note:** Enter a leading zero when entering a quantity less than 10.



## Changing the default settings

- To set the half-page reception for paper saving, select **"Half Page Rx"** using the cursor key and then press **ENTER**. The LCD will show:

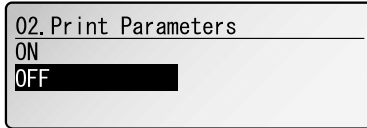

- Select **"ON"** or **"OFF"** for the half-page reception.
- When you finished your choice, select **"Exit"** and press **ENTER** to save the settings.

## Setting the number of rings

**Default setting:** 2 times.

You can set how many times your fax machine will ring before answering a call. Choose from 1 to 9 rings.

- Press **MENU, 2, 2, 0, 3, ENTER**. The LCD shows:

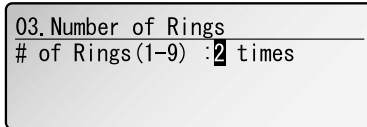

- Use the numeric keypad to enter the number of rings you want, from 1 to 9.  
**Note:** If you enter the number except 1-9, the machine will beep briefly to warn you that it can't accept that setting.
- Press **ENTER** to save the setting.

## Image Rotation

**Default setting:** OFF.

When this feature is activated, incoming fax messages will be rotated automatically to fit on the paper.

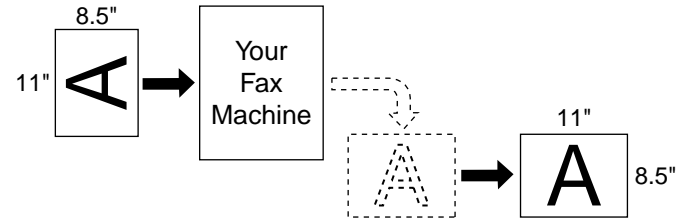

- Press **MENU, 2, 2, 1, 3, ENTER**. The LCD shows:

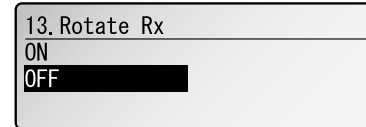

- Using the cursor key, select the mode you want. Then press **ENTER** to save the setting.

# Settings for dialing

## Changing the dialing pause length

**Default setting:** 2 seconds.

The pause is set by the factory to last two seconds, but you can set it to last as long as ten seconds if necessary. To change the pause length:

- 1 Press MENU, 2, 2, 0, 5, ENTER.

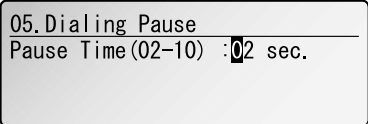

- 2 Use the numeric keypad to enter the length you want for the dialing pause.  
**Note:** The length setting requires two digits. Always enter a leading zero for lengths less than 10 seconds.
- 3 Press enter to save the setting.

## Changing redial settings

**Default setting:** Number of redial: 2 times, Redial interval: 1 minute.

It's up to you how many times the fax redials a number and how long it waits between redials (that length of time between calls is the *redial interval*).

To program the redial settings:

- 1 Press MENU, 2, 2, 0, 4, ENTER.

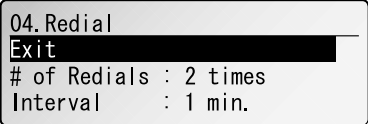

- 2 Using the cursor key, select “# of Redials” and then press ENTER.

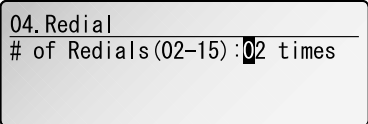

- 3 Use the numeric keypad to enter the number of redials you want, from 2 to 15.

**Note:** Enter a leading zero when entering a quantity less than 10.

**Note:** Also you can set the number of redials using ▲ or ▼.

- 4 When you finished the entering number, press ENTER.

- 5 Using the cursor key, select “Interval” and then press ENTER.  
The LCD will show:

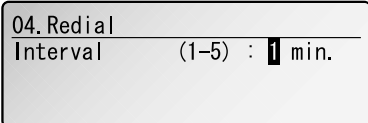

- 6 Use the numeric keypad to enter the length you want between redial attempts. Choose from 1 to 5 minutes.

**Note:** Also you can set the length between redial attempts using ▲ or ▼.

- 7 When you finished the entering number, press ENTER.

- 8 To save the setting, select “Exit” and then press ENTER.

# Settings for copying

## Scan settings

**Default setting:** Primary resolution: Fine, Primary contrast: Normal, Scan width: B4

Three different settings tell your machine how to scan documents. The initial factory settings are probably right for most applications, so try using them before changing any of these settings:

- **Primary resolution mode** — Sets the resolution for your documents. Choose either normal, fine, superfine (“S-Fine” on the LCD) or grayscale mode (“Gray”).
- **Primary contrast mode** — Sets how light or dark you want faxed documents to be when they arrive at their destinations.
- **Scan width** — Sets the scan width for your documents. Choose either B4 or A4.

**Note:** These settings you choose effect your copy activity only.

To set these modes:

- 1 Press **MENU, 2, 3, 0, 1, ENTER**. The LCD shows:

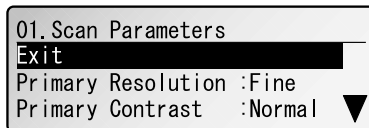

- 2 To set the primary resolution mode, select “**Primary Resolution**” and then press **ENTER**. The LCD will show:

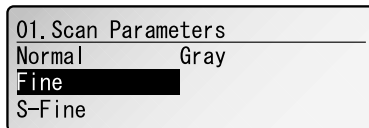

- 3 Select resolution mode you want to set using the cursor key, then press **ENTER**.

- 4 To set the primary contrast mode, select “**Primary Contrast**” and then press **ENTER**. The LCD will show:

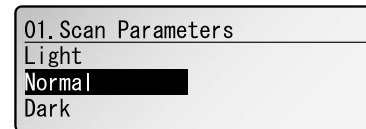

- 5 Select contrast mode you want to set using the cursor key, then press **ENTER**.

- 6 To set the primary scan width, select “**Scan Width**” and then press **ENTER**. The LCD will show:

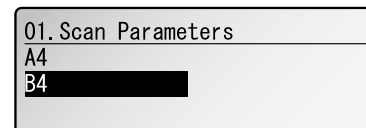

- 7 Select scan width you want to set using the cursor key, then press **ENTER**.

- 8 When you finished your choice, select “**Exit**” and then press **ENTER** to save the settings.

By following the steps above, you’ve set your *defaults* for scanning. Before making copies, you can “override” these default scan settings *for that copy*.

To *override* the default resolution and contrast settings before making copies:

- Press [**Mode**] to change the resolution.
- Press [**Contrast**] to change the contrast.

Once you made copies, your machine returns to its default settings.

# Copy print settings

You can set three print parameters for copy:

- Print reduction rate for copy
- Print margin for copy
- Bypass Tray priority

You set these three in the same procedure, discussed below. Following is an explanation for each:

## Print reduction rate

*Copy reduction* lets you set the machine to reduce large documents to a size that fits the paper in your machine. (This setting doesn't affect printing fax message you may receive with your machine.)

## Print margin

Your machine's *print margin* for copying is measured in millimeters (mm). We'll define *print margin* by explaining how it's used:

When an original document is scanned, the machine measures the document's length and compares it to: (a) the length of your selected paper (not include the print margins) plus (b) the print margin you set. If the length of the document is longer than (a) and (b) put together, your machine prints the document on more than one sheet.

**Note:** A print margin setting of 24 mm will print most documents as single pages. Try this combination first and then, only if you have problems with it, select different settings.

## Bypass Tray priority

If you set the same sized paper to both the paper cassette and bypass tray, and this mode is turned to on, the machine gives priority to use the paper which is set on the bypass tray than the paper in the cassette.

## To adjust the copy print settings

**Default setting:** Copy reduction rate: 100%, Margin: 24 mm, Bypass tray priority: Off

- 1 Press MENU, 2, 3, 0, 2, ENTER. The LCD shows the current print margin for copying:

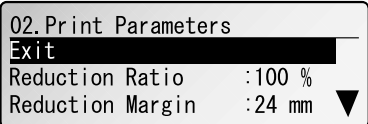

- 2 To set the reduction rate for copying, select "Reduction Ratio" using the cursor key and then press ENTER. The LCD will show:

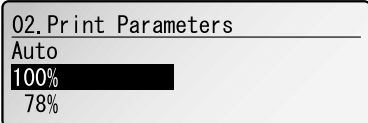

- 3 Using the cursor key to select Auto, 100% or 78% for the copy reduction setting. Then press ENTER.

- 4 To set the reduction margin for copying, select "Reduction Margin" using the cursor key and then press ENTER. The LCD will show:

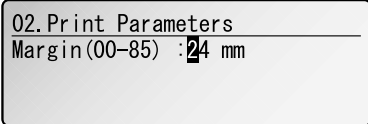

- 5 Use the numeric keypad to enter the print margin you want, from 00 to 85. Then press ENTER.

**Note:** Enter a leading zero when entering a quantity less than 10.

- 6 To set the bypass tray priority, select "Bypass Tray Priority" using the cursor key and then press ENTER. The LCD will show:

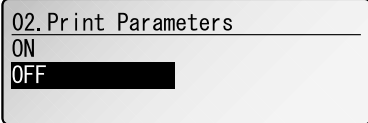

In case of the same size papers are set in the cassette and on the bypass tray, the cassette has a priority to supply papers. If you want the bypass tray to have a priority, select ON.

- 7 Using the cursor key to select "ON" or "OFF" for the bypass tray priority setting. Then press ENTER.

- 8 When you finished the setting, select "Exit" and then press ENTER to save the settings.

# Settings for operation

## Setting the silent mode

**Default setting:** OFF.

*Silent mode* allows you to mute the ringer, the alarm and the key tones.

- **Ringer Silent** — If you turn the ringer off in silent mode, a ring alerts you when you receive fax or voice call and a call request.
- **Alarm Silent** — If you disable the alarm in silent mode, the sound your machine makes when an error occurs and the beep your machine makes after sending or receiving a fax or making a copy cannot be heard.
- **Key Buzzer Silent** — If you mute the key tone, your machine will not make a sound when you press the buttons on the control panel.

**1** Press **MENU**, **2**, **1**, **0**, **4**, **ENTER**. The LCD shows your fax's current setting:

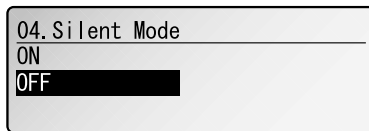

**2** Press **▼** or **▲** to select silent mode *On* or *Off*; and then press **ENTER**.

If you chose *On*, proceed to next step. The silent mode of *Ringer*, *Alarm* or *Key buzzer (Key tone)* can be set to be available.

If you chose *Off*, the machine will ring and beep as usual. Skip to step 9. You can adjust volume level.

**3** The machine asks if you want the ringer to be on or off.

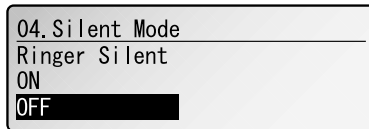

**4** Press **▼** or **▲** to select *On* or *Off*; and then press **ENTER**.

If you want to turn off the ringer, select "On".

**5** The machine now asks if you want the alarm turned on or off.

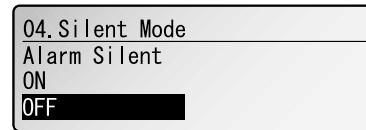

**6** Press **▼** or **▲** to select *On* or *Off*, and then press **ENTER**.

If you want to turn off the alarm, select "On".

**7** The machine now asks if you want the key tones on or off.

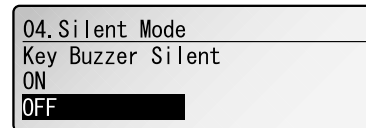

**8** Press **▼** or **▲** to select *On* or *Off*, and then press **ENTER**.

If you want to turn off the key tone, select "On". Otherwise, the machine will make a sound when you press the keys on the control panel.

If you turned off the alarm or the key tones in the step above, your machine gives you the option of setting the volume for the alarm and key tones. If this option appears, proceed to next step.

If you did turn all of silent mode to on, your machine exit this setting mode.

**9** Press **◀** or **▶** to select the mode you want, and then press **ENTER** to save the setting.

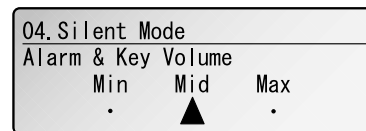

**10** Press **STOP** to return to the standby mode.

## Setting Sleep mode (Energy saving mode)

**Default setting:** On

**Note:** All LED lamps on the control panel will not be off, even when the machine is in the sleep mode.

If you want to change the Sleep mode to OFF, you can set it here.

**1** Press **MENU, 2, 1, 0, 5, ENTER**. The LCD shows:

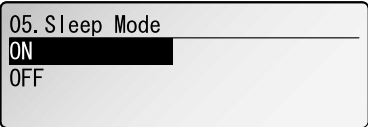

**2** Using the cursor key, select the mode you want. Then press **ENTER** to save the setting.

## Setting paper source

**Default setting:** 1st cassette: Fax/Copy, Bypass Tray: Fax/Copy

**1** Press **MENU, 2, 1, 0, 8, ENTER**. The LCD shows:

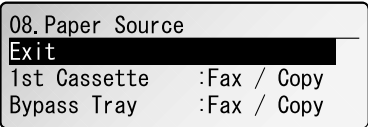

**2** Select the item you want to change the setting using the cursor key and then press **ENTER**. The LCD will show:

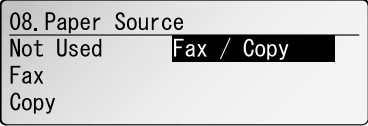

**3** Select **“Fax/Copy”, “Fax”** or **“Copy”** as you want. Then press **ENTER**.

**“Fax/Copy”:** Select this if you want to use the paper source you selected for faxing, list (or report) printing and copying.

**“Fax”:** Select this if you want to use the paper source you selected for faxing and list (or report) printing.

**“Copy”:** Select this if you want to use the paper source you selected for copying only.

**“Not Used”:** Select this if you do not want to use the paper source you selected.

If you want to change *another* setting, repeat steps 2 and 3.  
If you *do not* want to change any more settings, proceed to step 4.

**4** Select **“Exit”** then press **ENTER** to save the setting.

## Adjusting the machine’s clock

You can adjust the machine’s clock here.

**1** Press **MENU, 2, 1, 0, 7, ENTER**. The LCD shows:

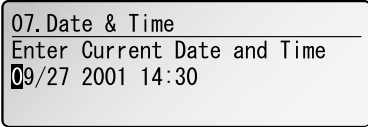

**2** Use the numeric key to enter the current date and time to adjust the clock. Then press **ENTER**.

## Setting 2-bin tray (Option)

**Default setting:** Copy exit: Lower tray, Fax exit: Upper tray, List exit: Upper tray

You will set where the printed paper emerges in this operation.

**Note:** This operation will appear only if the optional 2-bin tray has been attached to your machine.

**1** Press **MENU, 2, 1, 1, 0, ENTER**. The LCD shows:

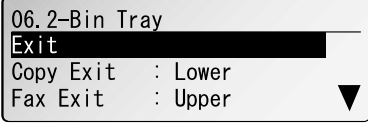

**2** Select the item you want to change the setting by using the cursor key and then press **ENTER**.

**3** Select **“Upper”** or **“Lower”** as you want. Then press **ENTER**.

If you want to change *another* setting, repeat steps 2 and 3.  
If you *do not* want to change any more settings, proceed to step 4.

**4** Select **“Exit”** then press **ENTER** to save the setting.

## Printing your settings

After you've programmed settings into your machine, print a *settings list*. We recommend this, particularly if you're sharing the machine with other users, who might change the settings.

With this list, you can quickly confirm that all of your settings are correct, without having to go back and check them on the machine. Or, if you *do* need to undo someone else's changes, this list guides you in returning the machine to your preferred settings.

To print the *User settings list*, press **MENU, 5, 1, 0, 2, ENTER**.

*This page intentionally blank.*



# Just in case ...

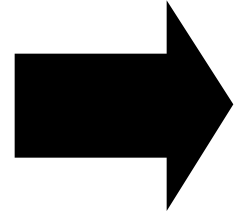

*Tips on caring for your machine*

*What to do if problems occur*

*Glossary*

Clearing paper jams .....	5.1
Print quality problems .....	5.3
Troubleshooting .....	5.5
Caring for your fax machine .....	5.11
Common questions .....	5.13
Glossary .....	5.16

# Clearing paper jams

## If an original document jams

- 1** If an original document jams in the ADF while scanning the document into the memory for faxing or copying, the LCD will show:

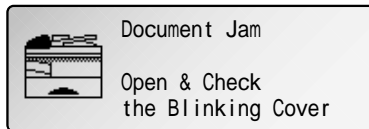

- 2** Open the scanner cover and remove the jammed paper (see next column). The LCD will show:

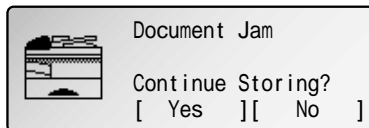

If you do wish to resume the operation, press **[Yes]** and proceed to step 3.

To abort the operation, press **[No]**. This will erase from memory all pages stored during this operation, and the machine will ask you to remove the jammed paper.

**Important:** If more than 60 seconds passes without pressing any key, the machine will erase from memory all pages stored during this operation and the machine will ask you to remove the jammed paper.

**Note:** If the document jammed in the following case, the machine would abort the operation. You'll have to perform the job again from the beginning.

- The first page of the document jammed
- During the quick memory transmission

Also, the "Repeat transmission. Error on scan at page xx" message will be printed out if the document jammed during transmission.

- 3** The LCD will show which page is jammed. Reset the document(s) from the jammed page forward, and press **START** to continue scanning.

Storing has not been Completed  
Reset Document from the  
Following Page and Press START  
Page No. 2

**Note:** If you wait more than 60 seconds without pressing a key, the machine will begin to send or copy the document(s) stored during this operation.

If you wish to cancel this operation, press **STOP**. The machine will delete all pages from memory and then return to its standby mode.

## To remove the document:

- 1** Open the scanner cover.  
If you can remove the document, remove it and skip to step 3.  
If not, proceed to step 2.

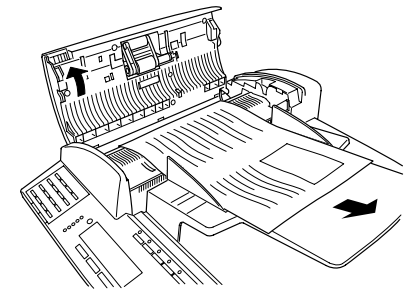

- 2** Open the inner cover and lift the document from the machine.  
**3** Gently close the scanner cover, making sure both sides are snapped down securely.

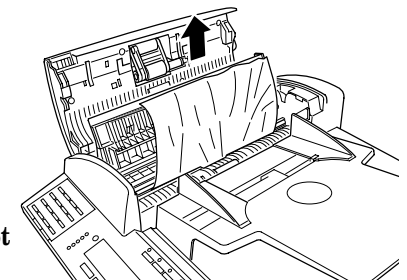

**Note:** If the original document has become wrinkled or torn, **do not** re-send it.

## If a printout jams inside your machine

To clear a printout jammed inside your machine:

**Important:** Be careful not to put your hand between the top cover and the machine.

**1** Open the top cover.

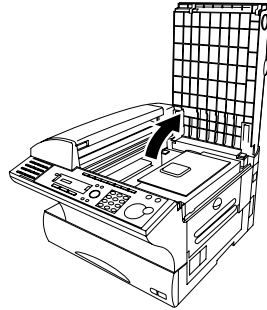

**2** Open the printer cover.

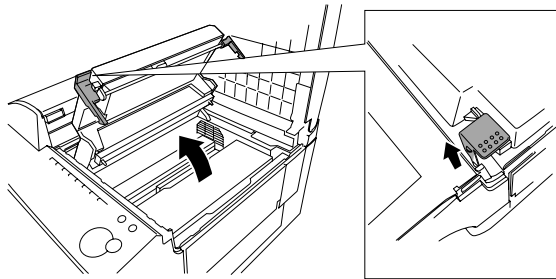

**3** Remove the toner and drum cartridge.

**Important:** Shield the drum cartridge from light, especially strong light. Later, if you have to remove the cartridge from the fax, immediately wrap it in a thick cloth to protect it from light.

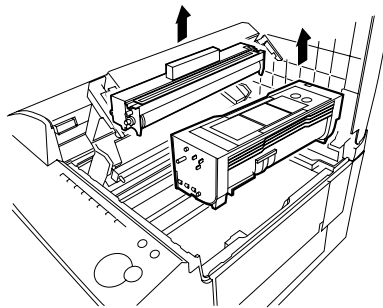

**4** Remove the jammed paper.

**⚠ CAUTION:**

The fuser unit becomes very hot.

**Do not** touch the fuser unit when you are removing a paper jam.

**Note:** Avoid getting “unfixed” toner on your hands and clothes.

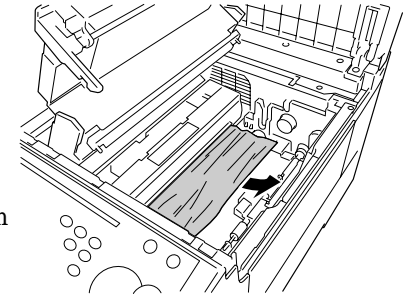

Open the side cover.

Raise the jam release lever to remove the jammed paper.

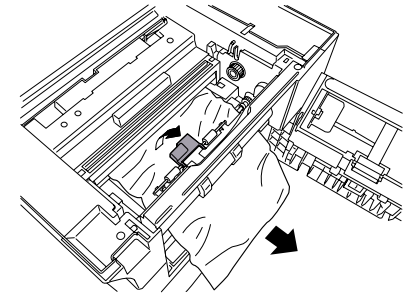

**5** Reset the toner and drum cartridge.

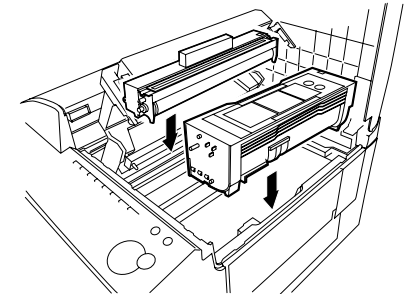

**6** Gently close the printer cover, pressing firmly on the both sides of the printer cover until you hear it click.

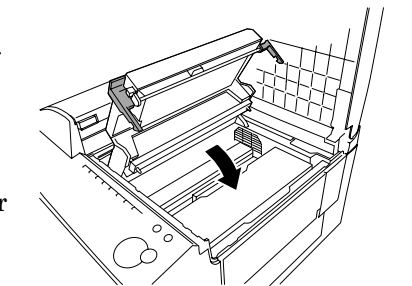

**7** Gently close the top cover, pressing firmly on the both sides of the top cover until you hear it click.

# Print quality problems

If your machine's printouts develop quality problems, try to find the example below that matches your printout problem. When you find one which is like yours, try the suggested solutions. If they don't work, contact your authorized Muratec dealer.

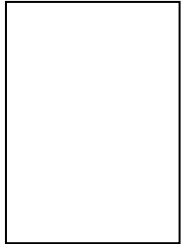

## Pages are blank

- The drum cartridge or toner cartridge may not be installed correctly.  
*Install each cartridge correctly.*
- The toner cartridge may be out of toner, or the toner may be very low.  
*Remove the toner cartridge and shake it a few times to redistribute the toner inside.*  
*If the problem persists, replace the toner cartridge.*
- The toner cartridge may be defective.  
*Remove the toner cartridge and check it for damage.*  
*If the problem persists, replace the toner cartridge.*

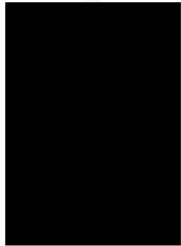

## Pages are black

- The toner cartridge may be defective.  
*Remove the toner cartridge and check it for damage.*  
*If the problem persists, replace the toner cartridge.*
- Your fax machine's printer may be due for a service check.  
*Call your dealer.*

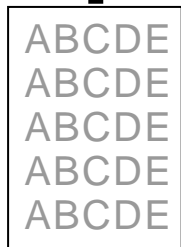

## Printouts are too light

- The toner cartridge may be out of toner, or the toner may be very low.  
*Remove the toner cartridge and shake it a few times to redistribute the toner inside.*  
*If the problem persists, replace the toner cartridge.*
- The toner cartridge may be defective.  
*Remove the toner cartridge and check it for damage.*  
*If the problem persists, replace the toner cartridge.*

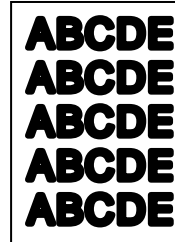

## Printouts are too dark

- The toner cartridge may be defective.  
*Remove the toner cartridge and check it for damage.*  
*If the problem persists, replace the toner cartridge.*

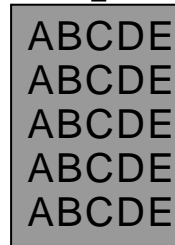

## Printouts have a blurred background

- The toner cartridge may be defective.  
*Remove the toner cartridge and check it for damage.*  
*If the problem persists, replace the toner cartridge.*

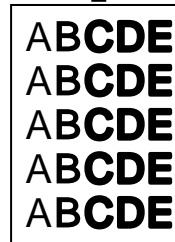

## Printouts are of uneven density

- The toner may be unevenly distributed inside the toner cartridge.  
*Remove the toner cartridge and shake it a few times to redistribute the toner inside.*
- The drum cartridge may be defective.  
*Remove the drum cartridge and check it for damage.*  
*If the problem persists, replace the drum cartridge.*

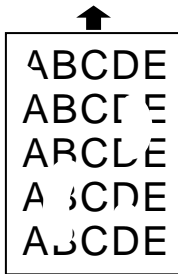

### Printouts have irregularities

- The paper you're using may have absorbed moisture, perhaps due either to high humidity or water having been spilled on the paper supply. Toner will not adhere well to wet paper.  
*Replace the paper with dry paper and try printing again.*

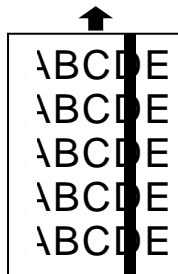

### Printouts have white and/or black lines

- The toner cartridge or drum cartridge may be defective.  
*Remove the cartridges and check them for damage. If the problem persists, replace either or both of the cartridges as indicated.*
- The LED print head may be dirty.  
*Using the cleaning paper, gently clean the LED print head.*
- The charger may be dirty.  
*Your machine normally cleans the charger automatically. If other solutions fail, please contact your authorized Muratec dealer.*

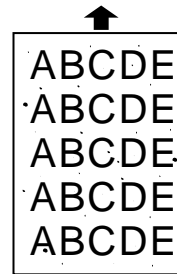

### Printouts have toner smudges

- The toner may be unevenly distributed inside the toner cartridge.  
*Remove the toner cartridge and shake it a few times to redistribute the toner inside. If the problem persists, replace the cartridge.*
- The toner cartridge or drum cartridge may be defective.  
*Remove the cartridges and check them for damage. If the problem persists, replace either or both of the cartridges as indicated.*
- If you find smudges on the back of the printouts, the transport roller may be dirty.  
*Your machine normally cleans the transport roller automatically. If other solutions fail, please contact your authorized Muratec dealer.*

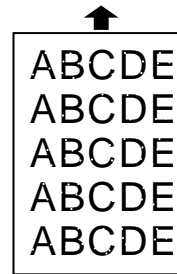

### Printouts have white spots

- The charger may be dirty.  
*Your machine normally cleans the charger automatically. If other solutions fail, please contact your authorized Muratec dealer.*

# Troubleshooting

Occasionally, your fax machine encounters some trouble transmitting or receiving documents. When it does, it alerts you with an alarm. You can identify the problem with LCD messages and printed *check messages* and *error reports*, explained in the following pages.

---

## Alarm

Your fax machine sounds an alarm tone — a series of short beeps — if either of these two problems occur:

- Trouble transmitting or receiving
- The machine is out of paper

---

## LCD error messages

*What you see on the LCD*

*What it means/What to do*

### 30 Locations or Less

You tried to enter too many numbers for broadcast through the numeric keypad. You can enter up to 30 locations by using numeric keypad for broadcast using. Press **CANCEL** to delete the extra numbers and then try again.

### All Commands in Use

Your fax machine has all of its 99 possible delayed commands (automatic redialing counts as one) stored in memory and cannot accept another. Wait until your fax has completed one of the delayed commands or delete an existing command by using **COMM.CANCEL/CONFIRM**.

### Already Stored

You tried to store the polling document in your fax machine, where one already had been stored. Wait for the fax to complete the regular polling operation or delete the stored document, then try again.

### Box in Use

You tried to erase a F-Code box which contains at least one document. Erase the document(s), then try again.

*What you see on the LCD*

*What it means/What to do*

### Call for Service

The scanner lamp is dim or inoperable. Make repeated copies to help evaporate any internal moisture. *If that doesn't resolve the problem, call your authorized Muratec dealer or Muratec Customer Support.*

### Check Memory Tx

You tried to turn the Fax&Copy feature ON, but the memory transmission setting is OFF. To use the Fax&Copy feature, the memory transmission setting must be set to ON. *Set the Memory Tx to ON, then try again.*

### Check Paper Size Open&Close Top Cover

The different sized paper which is not same sized paper you told your machine is loaded. *Set correct sized paper or change the paper size setting (see page 1.8–1.9).*

### Close Scanner Cover Close Top Cover Close 1st Side Cover Close 2nd Side Cover

The cover indicated on the LCD is open or has not been closed securely. *Close it properly.*

### Close 1st Cassette Close 2nd Cassette

The paper cassette indicated on the LCD is open or has not been closed securely. *Close it properly.*

### Communication Error

A communication error disrupted the reception or transmission. *If you were transmitting, press STOP to clear the error message and then re-try the transmission. If you were receiving a fax, try to contact the other person and have him/her re-try the transmission. (The problem may be entirely with his/her machine, phone line, etc.)*

### Document is being Polled

You tried to erase a document which someone is polling from your machine. *Wait for the fax to complete the polling operation, then try again.*

### Department Code Full

You tried to enter department code more than 100. Your machine can store up to 100 department codes.

Just in case ...

<i>What you see on the LCD</i>	<i>What it means/What to do</i>
<b>Document Full</b>	You tried to enter a document into an F-Code box or a Batch box, but the machine has reached its capacity. <i>Delete documents stored in box until the machine will let you proceed.</i>
<b>Document Jam</b>	An original document jam while you are using the ADF for either faxing or copying. <i>See page 5.1 for instructions on clearing the jam.</i>
<b>Document Stored</b>	A received document was in your fax's memory when you tried to turn off the security reception passcode. <i>Print the received document from your fax's memory, then retry the desired operation.</i> ... <i>or</i> ... You tried to erase a Batch box which contains at least one document. <i>Erase the document(s), then try again.</i>
<b>Drum Cartridge is Almost Empty</b>	Your drum will need to be replaced soon. <i>Please contact your authorized Muratec dealer to purchase a new drum cartridge if you don't already have one.</i>
<b>Hang Up Phone</b>	The optional handset is off-hook. <i>Hang it up, making sure the upper part of the handset presses down on the "hook" button.</i>
<b>In Relay Box</b>	You tried to store a document for polling in an F-Code box which is set to be a relay box. <i>Select an F-Code box which is set to be a bulletin box, then try again.</i>
<b>In Secure Box</b>	You tried to store a document for polling in an F-Code box which is set to be a security box. <i>Select an F-Code box which is set to be a bulletin box, then try again.</i>
<b>Invalid I.D. Code</b>	The F-Code box I.D. code you entered isn't valid. <i>Try re-entering your F-Code box I.D. code.</i>
<b>Invalid Number</b>	You pressed a key which has no function during the current operation.

<i>What you see on the LCD</i>	<i>What it means/What to do</i>
<b>Invalid Protect Passcode</b>	The protection passcode you entered isn't valid. <i>Repeat the operation, entering the correct protection passcode.</i>
<b>Memory Overflow Keep These Pages?</b>	During transmission (or copying), you tried to enter more pages into memory than your fax could store. <i>Press [YES] to tell your fax to keep as many pages in memory as possible, or press [No] to delete from memory all pages stored during this operation (but not previous operations).</i>
<b>No Command Stored</b>	You pressed COMM.CANCEL/CONFIRM to review upcoming commands, but your fax machine had none stored.
<b>No Department Code</b>	You tried to turn on the department code setting but there are no department codes stored in your fax machine. <i>Store at least one department code, then try again.</i> ... <i>or</i> ... You entered incorrect department code at fax sending while the department feature is on. <i>Enter correct department code.</i>
<b>No Document Stored</b>	You tried to print a document from memory, but your fax machine had none stored.
<b>No Drum Unit</b>	The drum unit is missing or has not been properly installed in your fax machine. <i>Please properly install the drum unit.</i>
<b>No Number Stored</b>	You selected an autodialer, batch box or F-Code box number for which there is no fax (or phone) number programmed. <i>Either choose another number or dial a phone number directly from the numeric keypad.</i>
<b>No Protect Passcode</b>	You tried to program a security feature (see page 3.46), but there's no protection passcode stored in your fax machine. <i>Store a protection passcode in your machine, then retry again.</i>

<i>What you see on the LCD</i>	<i>What it means/What to do</i>
<b>No Report</b>	You requested an activity journal or confirmation report, but your fax machine has no record of any fax jobs having occurred.
<b>No Toner Cartridge</b>	The toner cartridge is missing or has not been properly installed in your fax machine. <i>Please properly install the toner cartridge.</i>
<b>Not Allowed in Macro</b>	During macro registration, you pressed the key which cannot be registered in Macro, such as Monitor/Call key or Security Reception key.
<b>Open Top Cover Please Remove Paper Open 1st Side Cover Please Remove Paper Open 2nd Side Cover Please Remove Paper Open Top/2-Bin Cover Please Remove Paper Remove Bypass Paper Open&amp;Close Top Cover</b>	The paper is jammed in your fax machine. <i>Open the cover indicated on the LCD, and remove the jammed paper carefully.</i>
<b>PIN is not Stored</b>	You selected "Mode1" in the PIN mask feature and tried to call an autodialer number in which no PIN has been entered, or to call using numeric keypad without PIN. <i>Enter a PIN, then try again.</i>
<b>Please Call Service</b>	The printer unit of your fax machine has become inoperable. <i>Call your authorized Muratec dealer or Muratec Customer Support.</i>
<b>Please Wait</b>	Your fax machine's printer is either warming up or busy. <i>Please wait until the fax is finished printing and then re-try your command or operation.</i>
<b>Printer in Use</b>	The command you're trying to enter requires the use of the printer, which is already in use. <i>Wait for the fax to finish printing, then try again.</i>

<i>What you see on the LCD</i>	<i>What it means/What to do</i>
<b>Replace Drum : Unable to Print</b>	Your drum cartridge doesn't work. Your machine cannot print until it is replaced with a new drum cartridge. <i>Replace it.</i>
<b>Replace Toner : Unable to Print</b>	Your toner cartridge is empty. <i>Replace the toner cartridge. Your machine cannot print until it is replaced with a new toner cartridge.</i>
<b>Scanner in Use</b>	The command you're trying to enter requires the use of the scanner, which is already in use. <i>Wait for the fax to complete the scan, then re-try the desired command.</i>
<b>Security Rx is Off</b>	You tried to turn the security reception ON using a Soft key which is assigned to set the security reception to ON or OFF, but security reception setting has not set to on. <i>To turn on or off the security reception using a Soft key, first set the security reception setting to on. (See pages 3.46-3.47.)</i>
<b>Select Group Number (0-32)</b>	You tried to enter a call group number greater than 32. Your machine can maintain 32 call groups, numbered 1-32 (call group 0 covers all the groups). <i>Determine the correct call group identifier number and enter it, instead.</i>
<b>Toner Almost Empty</b>	Your machine is almost out of toner. <i>Please contact your authorized Muratec dealer soon to purchase a new toner cartridge if you don't already have one.</i>
<b>Too Many Characters</b>	You attempted to enter too many numbers or other characters in the current operation. <i>Press CANCEL to delete the extra characters, then try again. You may wish to review the operation's appropriate instructions.</i>
<b>Too Many Steps</b>	You tried to enter too many steps for a macro. You can enter up to 60 steps into a macro key.



## Just in case ...

*What you see on the LCD*

### Used in P One-Touch

What it means/*What to do*

You tried to erase the F-Code box or Batch box, which is programmed in the programmable one-touch key.

*Erase the programmable one-touch key that contains the F-Code box or Batch box you want to erase, then try again.*

## Errors

When sending faxes, your machine occasionally runs into *communications errors*. These can be caused by anything from lightning to telephone line interference. (These same factors cause the static, or *line noise*, you sometimes hear on phone calls.) They also can be caused by problems with the fax machine at the other end of the line.

Often, simply trying your call again is all that's necessary. However, *if the problem persists regularly*, call your local telephone company for help. If that doesn't help *and the problem persists regularly*, call your authorized Muratec dealer.

## Error reports

When an error occurs, your fax machine prints an *error report*. Each fax error report lists an *error message* which includes:

- A possible *solution* to the problem
- The *sending location* (if the remote fax stores a Location ID of its own)
- The *result* — which is a special *error code*.
- A *sample* of the document's first page.

## Kinds of error codes

The error code listed in the "Result" column of the error report indicates the specific problem encountered:

- "D" codes — Occur while *dialing*
- "R" codes — Occur during *reception*
- "T" codes — Occur during *transmission*

## Specific errors

Following are some error codes you may see on an error report:

### *Dialing errors*

- D.0.3, The remote unit didn't respond, the call couldn't be completed or **STOP** was pressed during dialing. *Re-try the call. If your machine repeats the message, call the remote fax unit's operator and verify that unit is operating properly.*
- D.0.2 The remote unit is busy. *Try the call again.*
- D.0.6, Either the remote unit didn't respond, the call somehow didn't go through or
- D.0.7 **STOP** was pressed during dialing. *Try the call again.*

*Reception errors*

- R.1.1 The calling fax machine didn't respond to your fax machine. This can happen if someone dials a wrong number or if the remote machine restricts access through use of a passcode.
- R.1.2 The two fax machines were incompatible. Your fax machine sends and receives only ITU-T Group 3 (see Glossary, page 5.17) fax communication, the industry standard since the early 1980s.
- R.1.4 Someone pressed **STOP** at the receiving fax machine.
- R.1.5 The fax machine didn't detect the silence at the end of the call for receiving an RCR.
- R.2.3 Poor phone line conditions made fax communication impossible. *Call someone at the remote machine's location.*
- R.3.1 The sending fax machine detected too many errors from the receiving fax machine.
- R.3.3 The sending fax machine is incompatible or had a document feeder problem during transmission.
- R.3.4 Poor phone line conditions may have prevented your fax machine from properly printing some or all of the pages it received.
- R.4.2 Either the line disconnected before transmission or the transmitting fax machine needs maintenance.
- R.4.4 The fax machine has reached its memory capacity.
- R.5.1, R.5.2 ECM reception failed (perhaps due to line noise).
- R.8.1 A compatibility error occurred.
- R.8.10 Line noise or other problems prevented line probing.
- R.8.11 The fax machine timed out while waiting for the retrain signal.

*Transmission errors*

- T.1.1 The remote fax machine didn't respond to your machine. *Call someone at the remote machine's location.*
- T.1.2 Your fax machine's page counter detected a possible document feeder error. *Carefully put the document back into the feeder and try the call again.*
- T.2.1 Either the phone line disconnected during transmission or fax communication became impossible due to bad phone line conditions. *Try the call again.*
- T.2.2 The two fax machines were incompatible. Your fax machine sends and receives only ITU-T Group 3 (see "Glossary," page 5.17) fax communication, the industry standard since the early 1980s.

- T.2.3 Bad phone line conditions made fax communication impossible. *Conditions can change rapidly, so try the call again later.*
- T.3.1 The page counter in your fax machine detected a document feeder error during transmission. *Carefully re-insert the document into the feeder and re-try the call.*
- T.3.2 The fax machine didn't detect the silence indicating the call had ended.
- T.4.1 The telephone line disconnected during transmission because of excessive modem errors or because remote unit ran out of paper. *Try the call again.*
- T.4.2 After transmission began, poor line conditions developed. *Try the call again.*
- T.4.4 Poor line conditions prevented transmission. *Try the call again.*
- T.5.1, T.5.2, T.5.3 ECM transmission failed (perhaps due to line noise). *Conditions can change rapidly, so try the call again later.*
- T.8.1 A compatibility error occurred.
- T.8.10 Line noise or other problems prevented line probing.
- T.8.11 The remote fax machine didn't complete the equalizer training phase.

## “Check Message” printouts

When there’s a problem with a fax call and your machine detects an error, it produces an error printout headed by the words “Check Message.” This printout lists the following information about the transmission:

- The resulting error code
- A communications error message (see “What error messages can mean,” below)
- The phone number (or TPI, if programmed) of the fax machine with which your machine had attempted to communicate.

### *What error messages can mean*

The error messages on Check Message printouts can mean a variety of things. Here’s a brief summary:

<b>Error message</b>	<b>Possible meanings</b>
Check condition of remote fax.	<ul style="list-style-type: none"><li>• Remote machine malfunctioned</li><li>• No “handshake” signals from remote fax</li><li>• Wrong phone number reached</li></ul>
Repeat transmission.	<ul style="list-style-type: none"><li>• Poor phone line conditions</li><li>• No “handshake” signals from remote fax</li><li>• Document misfeed or miscount</li><li>• Unable to reach remote machine after attempting specified number of redial tries</li></ul>
Line is busy.	<ul style="list-style-type: none"><li>• Remote machine’s line was busy</li><li>• Remote machine’s line didn’t answer</li></ul>
Check received documents.	<ul style="list-style-type: none"><li>• Remote confirmation signal not received from remote fax</li><li>• Poor line conditions caused a poor image</li></ul>
Memory full.	<ul style="list-style-type: none"><li>• Remote fax’s memory is full</li></ul>
Dialing number is not set.	<ul style="list-style-type: none"><li>• Stored phone number failed to dial properly</li></ul>
Stopped.	<ul style="list-style-type: none"><li>• Someone pressed <b>STOP</b> at the remote fax in the middle of the “handshake”</li></ul>

# Caring for your fax machine

With proper installation and a little maintenance, your fax machine should give you dependable service for years to come.

Although it requires little day-to-day care, you can take these simple precautions to keep it in top form:

- **Always** make sure your fax machine is installed according to our specifications, including using an electrical surge suppressor. (If necessary, review “Pick an installation spot,” page 1.5.)
- **Always** use good, copier-quality paper.
- **Always** clean your fax machine as needed (see “Cleaning tips,” below).
- **Never** install your fax machine where it can overheat, gather dust or get splashed by any liquids (even water).

---

## Cleaning tips

Some things to keep in mind about cleaning your fax machine:

- **Clean it!** Dust and dirt, especially around the fax machine’s air vents can shorten your machine’s life.
- **Always** unplug the fax machine *before* you clean it.
- **Never spray any cleaner DIRECTLY onto your fax machine.** The drifting spray could damage components inside.
- **Never try to clean SEALED areas inside your fax machine.** They’re sealed to protect your safety and the machine.
- For cleaning *external* surfaces, such as the cover and handset: use a mild cleaning solution sprayed onto a lint-free towel or cloth.
- **Always** use a lint-free cloth (or swabs) moistened with alcohol to *gently* wipe components inside your machine.
- In areas you can’t reach with swabs, **always** use dry, dust-free compressed air to *gently* blow away dust and other material.

## Corrective cleaning

Here are some simple cleaning procedures for keeping your fax machine operating smoothly. Use each as the need arises.

### Curing frequent jams in the ADF

If you’re having trouble with getting your original documents to feed properly, try this procedure:

- 1** Turn off your fax machine.
- 2** Get two soft, lint-free cloths and moisten them as follows:
  - One with a cleaner suitable for use on platen/rubber rollers. In steps 4 and 6, we’ll call this the rollers cleaner.
  - The other with isopropyl alcohol
- 3** Open the scanner cover by holding the scanner cover release.  
**Important:** You must hold the cover open. It won’t stay open by itself.
- 4** Use the cloth with the rollers cleaner to clean the face of the rollers. Rotate the rollers by hand to allow cleaning of the entire roller surface.

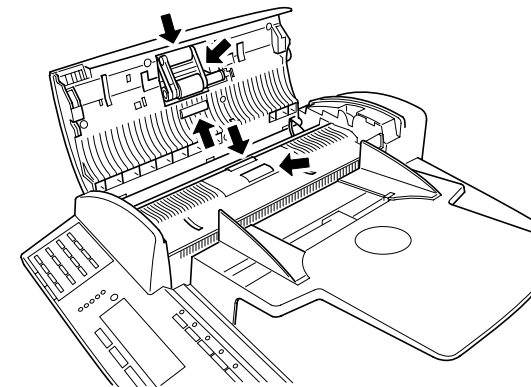

- 5 Open the inner cover fully.

**Important:** You must hold the cover open. It won't stay open by itself.

- 6 Use the cloth with the rollers cleaner to clean the face of the rollers. Rotate the rollers by hand to allow cleaning of the entire roller surface.

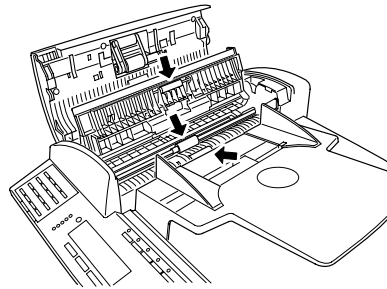

## Cleaning the LED print head

If you find your fax recipients complaining that the faxes you receive or copy image quality are streaked, the LED print head may be dirty.

**Important:** Be careful not to put your hand between the top cover and the machine.

- 1 Turn off your fax machine.
- 2 Get a soft, lint-free cloth and moisten it with isopropyl alcohol.
- 3 Open the top cover and then open the printer cover.

**⚠ CAUTION:**

The fuser unit becomes very hot.

**Do not** touch the fuser unit when you are cleaning the LED print head.

- 4 Using the cloth, gently clean the LED print head.

**Note:** **Do not** use abrasive materials on the LED print head, and **do not** subject the LED print head to strongly shock.

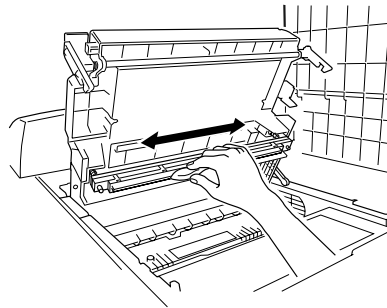

## If you have unsatisfactory printout quality

Your machine automatically cleans its charger and transport roller, two items which are very important to printout quality. So, if you notice poor printout quality (whether on received faxes or on copies), it may mean that your machine requires service. Review "Print quality problems" (pages 5.3-5.4), and see whether any of the proposed solutions helps your machine. If none do, please call your authorized Muratec dealer or call the Muratec Customer Support Center at (800) 347-3296 (from the U.S. only).

# Common questions

## We're here to help you!

The *Muratec Information System* is available to you 24 hours a day, 7 days a week. You can use your fax machine to call this “fax-on-demand” system and receive printouts of information, such as the most common questions asked about your machine. Often, *this* is the fastest way to find out the answer to any question you may have. And it's a free call!

To use the Muratec Information System:

- 1** On your fax machine, press **MONITOR/CALL** to get a dial tone, or lift your optional handset.
- 2** Call **1-800-215-1698**.
- 3** Follow the voice instructions you'll receive from the system.

## General questions

- Q:** Where do I add ink or toner to make my fax machine's printouts darker?
- A:** *You can't adjust the darkness of an incoming fax printout, but you can adjust the darkness of a copy or of a transmission. Insert a document and press **CONTRAST** to adjust the contrast setting. “Dark” prints at the darkest setting. The machine will reset automatically to normal contrast after you finish copying or sending the fax.*
- Q:** When I unplug my machine or if the power goes off, will I lose the information I've stored — such as my TTI, autodialer entries, the time and date, etc. — and have to re-enter them?
- A:** No. There's a special battery built into your fax machine which protects user settings for several days if power fails or if you decide to move your machine. However, we do advise you to restore power to the machine as soon as possible.
- Q:** Can I use a dust cover on my fax machine?
- A:** No! A dust cover blocks air circulation, which could cause your machine to over-heat.

## Sending faxes

- Q:** Sometimes, I try to send a fax while using either the optional handset or the **MONITOR/CALL** feature. But, when the other side answers, I hear a horrible screeching sound, so I hang up. What's happening?
- A:** That was the other fax machine trying to say “Hello” to your machine! You'll hear sounds like that any time you call a fax machine which is set to answer automatically (as when you set your machine to Auto Answer mode). It's by using these tones that fax machines are able to send faxes over ordinary phone lines. So, next time you hear the tones, press **START** (and, if you're using an optional handset, hang up) to send a fax.
- Q:** I just sent a fax. However, the number that appeared in my machine's display during the transmission wasn't the number I dialed. Why?
- A:** That number you saw is programmed into the remote fax machine by the user. Some users prefer different numbers to appear than the ones they're really using. And some people don't know how to change the number once it's set.
- Q:** Can I transmit and receive at the same time?
- A:** No. Use the call request feature (see pages 3.26–3.27) to ask the person at the remote fax machine if he or she wants to transmit or receive after your fax communication is complete.
- Q:** Do I have to dial a *1* for a long-distance call?
- A:** Yes. Dialing a fax number is just like dialing any other phone number, so be sure to include any special long-distance codes or dialing pauses when dialing. Also, remember to include them when you set your autodialer numbers.
- Q:** How do I send a fax to an overseas telephone number?
- A:** Dialing requirements for international calls may vary depending on your local telephone company's requirements. For most international calls, call *011*, then dial the appropriate country code, city code and phone number. (You may find country and city codes in the front section of your telephone directory.)
- Q:** Can I transmit if my fax machine runs out of paper?
- A:** Yes, but confirmation reports (see page 3.23) aren't available when you transmit without recording paper in your fax machine.

- Q:** Can I transmit a document that's extra long?
- A:** Yes, *if* the receiving fax machine is equipped to handle long documents. Many machines have a special setting which allows them to receive documents that exceed the normal length.
- Q:** Can I transmit a page from a newspaper?
- A:** No. A newspaper page can jam in your document feeder. First, use a copy machine to make an appropriately sized copy of the newspaper page, then transmit the copy.
- Q:** Can I transmit a page with correction fluid on it?
- A:** Yes, but only if the fluid is *completely dry* before you begin transmission.
- Q:** How can I be sure my fax was received?
- A:** Set your machine to print a confirmation report after each transmission (see pages 3.23).
- Q:** I don't want to install a dedicated phone line for my fax machine, so I've connected the machine to a PBX phone system. When I get a fax call, *all* the phones ring. How do I prevent this?
- A:** Call your PBX manufacturer or telephone company for assistance. They may be able to convert one of the PBX lines for use only by your fax machine.
- Q:** Sometimes when I dial a fax call by using either the optional handset or **MONITOR/CALL**, I don't hear the fax receiving tones from the other machine. Am I doing something wrong?
- A:** When this happens, try pressing **START** (and then hanging up the optional handset if you're using it), as usual. It's possible you're calling an older, non-standard fax machine that *doesn't* emit answering tones. Even a few Group 3 faxes (see "Glossary," page 5.17) on the market sound a *sending* tone but don't sound a *receiving* tone. After you transmit, call the person at the other fax machine's location to see if that person got your document.
- Q:** I inserted a document in the feeder and dialed a fax number, but my machine didn't transmit the document. Instead, "**\*\* Auto Redial \*\***" now appears on my LCD. What does this mean?
- A:** The remote fax machine was busy, so your machine will try the call again, automatically. As long as it hasn't stored more than 99 delayed commands (counting automatic redials), your machine should still accept commands from you. If it has exceeded this quantity and will accept no more commands, try canceling one of the delayed commands (see page 2.6). If the machine *still* won't cooperate, keep canceling commands until it does.

- Q:** The specifications (page AI.1) list an average per-page transmission time, but when I transmit a page it can take much longer. Why?
- A:** We base this specification on transmission of an industry-standard test document called *ITU-T Test Document 1* (sometimes also called the "Slerexe letter"). Fax manufacturers use this method to test transmission speeds. However:
- The pages you send may be darker, or otherwise contain more information, than ITU-T Test Document 1.
  - The transmission time measured for test documents doesn't include *handshake time* — the time during which two fax machines "introduce" themselves to each other and "agree on" the parameters of the call.
  - The specification time is based on the use of normal resolution mode. You may be using fine, superfine or grayscale transmission, each of which takes longer than normal mode.
- Q:** What's a *default*?
- A:** A default is a setting that your machine will always refer to if nothing else is programmed. For example, you can set the default for this machine to send a fax by using its memory. If you set this action as the default, that's how your machine will always send a fax, until you tell it to do differently.

---

## Reports

- Q:** I called the number *011-555-555-1212*, but not all of the digits appear on my transmit confirmation report (TCR). Why didn't the whole number appear? How can I be sure my document went to the right location?
- A:** The numbers you enter using the fax keypad are temporarily stored in a memory "buffer", and it's only the last part of the phone number that the buffer "remembers." An easy way to avoid getting incomplete telephone numbers on your printouts is to store your most frequently used numbers as one-touch keys or speed-dial numbers. These autodialer numbers will appear in their entirety on your TCR.

## Receiving faxes

- Q:** My fax never answers. What's wrong?
- A:** Check to make sure your fax machine is properly connected to a working AC power outlet and phone jack (see page 1.7). If you're using a second phone with your machine, make sure *it's* connected properly (page 2.13).
- Q:** Sometimes when I answer my machine with the optional handset, I hear a beeping sound that repeats every few seconds. Is this a fax?
- A:** Yes. When you hear these *fax tones*, someone is trying to send you a fax. Next time, press **START** and hang up the handset. Your fax will receive the message.
- Q:** Does my fax machine have to be plugged in to the AC power jack to receive a message?
- A:** Yes. Your phone will ring if the phone line is connected, but you can't receive a fax unless your fax machine is plugged into both the phone jack and the AC power jack. Make sure your fax machine is always plugged in so you never miss an important fax message.
- Q:** Can I receive a fax if I'm using the phone on my machine?
- A:** You can receive a fax from the person to whom you're talking. When that person has a document ready in his/her machine's feeder, press **START**.

---

## Working with your answering machine

- Q:** People have complained that they call my fax machine and hear my answering machine's message, but are cut off before they can send a fax. What happened?
- A:** Any remote fax machine attempting to send a fax must "hear" responding fax tones within 40 seconds after the person at that machine presses the start key. That 40 seconds includes getting the dial tone, dialing the number, "listening" to the pause before the ringing starts and the remote fax machine answering the ring. Only after that time does your message play.
- That's why we urge you to create a short outgoing message. The shorter the waiting period, the more likely it is that the remote fax machine will proceed with the transmission. Please create an outgoing message on your answering machine that's no longer than 10 seconds (see page 2.9 for a suggestion).

## Polling

- Q:** What's the purpose of polling?
- A:** Polling lets you automatically "pull" a document which is set in another fax machine. You can poll whenever you need to retrieve information and don't want the source to pay for the phone call. With polling, you pay for the call and get the information you need.

---

## How your fax machine works

How a fax machine works is simple:

You put a page into your fax machine's feeder and call a fax number. Your machine makes a satisfactory connection with the other machine, and then ...

- *Your machine takes the document.*  
An image scanner in your fax machine examines the information on the page.
- *Your machine wraps the document.*  
Your fax machine translates the scanned information into a numeric code and compresses the code for the fastest possible transmission speed.
- *Your machine sends the document.*  
Finally, your fax machine sends the compressed code.

On the other end of the line ...

- The remote fax machine *receives* the code.
- Your machine *unwraps* the document.  
The remote fax machine uncompresses and deciphers the code, turning it into a representation of the scan your machine made.
- The remote fax machine prints the representation.

The only difference between a regular telephone call and a fax call is the *content* of the transmission:

- On a regular call, your telephone sends your voice.
- On a fax call, your fax machine sends a coded image.

The way fax machines work is regulated closely by the International Telecommunications Union (ITU), an agency of the United Nations. The standards the ITU applies ensure the compatibility of your fax machine with millions of other machines worldwide. However, they also limit the way you can use your machine with other devices, such as telephones and answering machines.



# Glossary

This glossary contains terms you may encounter when discussing or reading about fax machines. Please use these definitions for reference only. A list of definitions can also be found on the Muratec website at [www.muratec.com](http://www.muratec.com).

**24-hour format** — Also called *military format*. A format for keeping time that does not use a.m. or p.m. to distinguish between morning and afternoon. In the 24-hour format, one o'clock in the morning marks 1:00, noon marks 12:00 and midnight marks 24:00. To calculate the 24-hour format, add 12 hours to all times after noon.

For example, *1:30 p.m.* would be *13:30* in the 24-hour format; *10:45 p.m.* would be *22:45* in the 24-hour format. And *11:15 a.m.* would be *11:15* in the 24-hour format.

**A3, A4, B4** — Standard stationery sizes defined by the International Standards Organization, an agency of the United Nations. See also *Paper sizes*.

**ADF** — Automatic document feeder. See *document feeder*.

**Alternate number** — The number your machine dials after all attempts to the regular number fail. The user programs this alternate number, if so desired.

**Answering machine** — See *TAD*.

**Autodialing** — Enables user to store preprogrammed telephone numbers in the unit's memory. Storage capability varies from unit to unit.

**Automatic fallback** — The ability of a fax machine to slow down ("fall back"), when communicating with another fax which is communicating at a slower rate.

**Automatic reduction** — Many Muratec fax machines will automatically reduce the size of documents being transmitted to accommodate the effective printing width of the receiving unit. For example, this allows a fax machine with a 10" (256 mm) scanning width to send an image 10" (256 mm) wide to a unit with an 8.3" (210 mm) print width. The receiving fax machine will receive a reduced-size printout of the complete image.

**Bit** — The smallest unit of information in a computer. Some Muratec fax machines, which are actually computers "dedicated" to telecommunications, allow users to change bits of information to provide or cancel features through software settings.

**Bits per second** — See *bps*.

**Black density** — Also called *black coverage*. The amount of non-white area on a page. For example, most regular office correspondence has a black density well under 10%, due to the presence of margins, spaces between words, spaces between lines and paragraphs and even spaces within letters. However, drawings and photographs have a much higher black density, sometimes approaching 100%. The higher a page's black density, the more slowly a fax machine sends it.

**Broadcast** — A fax transmission in which a single document is sent to more than one location.

**bps** — Bits per second. Used to express the speed of transmission of data. Because fax transmission treats a document as a graphic image rather than as a series of alphabetic and numeric characters, bps does not correspond to the number of characters transmitted per second.

**Byte** — A group of digital elements, usually sent as eight bits to the byte.

**Call reserve** — Also called *call request*. An ITU-T standard fax feature which allows a user to request voice communication prior to, during or after transmission.

**Call-waiting service** — An optional telephone company service that alerts you to another incoming call when the phone is already in use. Call-waiting signals often cause interruption of fax transmission or reception.

**Caller ID** — Optional service provided by your local telephone company that allows you to see a display of the number (phone or fax) that is calling.

**CCITT** — See *ITU-T*.

**CCD, CIS** — Charged coupled device, contact image sensor. Two types of scanning mechanisms used in some Muratec fax machines. The CCD "reads" fluorescent light bouncing off a document. The CIS uses a flat bar of light-emitting diodes (LEDs).

**Command queue** — The "list" your machine keeps of all its pending commands.

**Command number** — The number your machine gives to each "job" it is programmed to complete. You must know the command number in order to cancel or change any of the machine's jobs that it stores.

**Compatibility** — The term "compatible" describes the ability of separate things to function together. Your Muratec fax machine features ITU-T Group 3 compatibility, the modern standard for worldwide communication.

**Confidential transmission** — See *SecureMail*.

**Confirmation report** — See *RCR* and *TCR*.

**Continuous polling** — See *Polling*.

**Copy mode** — Allows your fax machine to be used as a convenience copier.

**Cover page (automatic)** — A small, user-created message; can be the first page of every transmission.

**Database polling** — See *Polling*.

**Data compression** — Used in digital fax machines to speed transmission. See also *Digital fax*, *MH* and *MSE, SMSE*.

**Default** — The setting your machine will always refer to if no other action has been programmed. For example, you can set the default for this machine to send a fax by using its memory. If you set this action as the default, that's how your machine will always send a fax, until you tell it to do differently.

**Delayed command** — Transmission or polling operation set by the user to occur later, automatically, at a predetermined time. Great for reducing costs by making fax calls during times when telephone costs are lowest, such as late at night or on weekends.

**Digital** — Using the binary system (which uses a combination of *0s* or *1s*) to describe everything, so that *0* means *off* and *1* means *on*; digital fax machines convert the graphic image of your document into a series of zeros and ones by using the binary system of transmission to encode black and white occurrences. This increases transmission speed by passing over white spaces. See also *White-line skip*.

**Digital fax** — Unlike analog systems that scan every portion of a document, digital fax machines survey a document's overall picture content. Digital fax machines scan a line and convert the information into a binary code of zeros and ones. The fax machine takes this information and compresses it, providing high transmission speeds. Many Muratec units offer proprietary methods for faster transmissions between Muratec-manufactured units (see also *MSE*, *SMSE*).

**DIP switches** — Dual in-line package switch; a two-position on/off switch. Many Muratec fax machines include DIP switches to control optional settings or features.

**Document feeder** — The adjustable slot into which users place documents for faxing or copying.

**Effective printing width** — The widest image that can be printed on a fax.

**Effective scan width** — The maximum width the scanner in a fax can scan during transmission.

**F-Code** — A fax-industry standard created by the ITU-T for sub-addressing/password-based communications. Because F-Code is an industry standard, Muratec fax machines as well as all ITU-T equipped fax machines from other manufacturers can communicate with each other using sub-addressing.

**Facsimile (or fax)** — A form of communication involving the scanning and decoding of a document into electrical signals and transmitting of the document, over telephone lines to another device. This device then reconstructs the signals to produce an exact duplicate of the document. Also, a machine that performs such communication.

**Fallback** — Group 3 fax machines operate at the highest transmission speed possible on a given telephone line. Muratec systems offer automatic fallback; if line quality drops during transmission, the fax machine will reduce speed to the fastest possible level.

**File number** — A number the machine gives to each document it stores for a batch, F-Code or polling operation.

**Fine resolution** — 203H × 196V lpi. Also shown as *G3F* ("Group 3 fine") on some fax units.

**Grayscale** — Not a level of resolution, but a method of scanning and transmitting halftone images. Fax machines with grayscale abilities interpret photographs in levels of gray between white and black. The transmitting fax machine must have grayscale ability to send a photographic image accurately, but the receiving machine does not need it to print the image.

**Group 3** — Refers to fax machines that use digital encoding. These units transmit one page in less than one minute and produce resolution of 203 × 98, 203 × 196, or 406 × 392 lpi.

**Halftone** — See *Grayscale*.

**Handshaking** — An exchange of data between telecommunications and/or computer equipment that "introduces" two systems to each other. For example, faxes use a handshaking protocol to identify the ITU-T group of each unit and to begin fax communication.

**Hub** — See *Relay broadcasting*.

**Hz (or Hertz)** — A measure of frequency equal to one cycle per second. Used in the specifications for a fax machine, it identifies the AC power the unit requires.

**ITU-T** — International Telecommunications Union – Telecommunications Sector. (Formerly known as *CCITT*, for *Consultative Committee for International Telegraph and Telephone*.) A telecommunications forum for member countries of the United Nations whose Study Group XIV established the primary groups for fax equipment, covering communication protocol and transmission. Muratec Group 3 fax machines offer the fastest transmissions allowed by the ITU-T when communicating with other Group 3 units.

**ITU-T Test Document 1** — Also called the *Slerexe* ("*slehr-rehks*") letter; An ITU-T standard document with a known black density which fax makers often use to test transmission speeds of their fax machines. Published transmission speeds are also based on this document.

**ITU-T v.29 and v.27 ter.** — A standard set of communication procedures allowing fax machines to talk to all other units adhering to those standards.

**JBIG** — Joint Bi-level Image experts Group, the new ITU-T standard image data compression method. As JBIG compresses the data more efficiently than MMR, it is especially effective when transmitting halftone (grayscale) image document. (Of course, the compression ratio may vary with the image data.)

**Laser printing** — A plain-paper printing system. Toner is attached to a charged drum and an image is transferred onto plain paper through electrical currents, then fused with heat and pressure to produce a dry, permanent printout.

**LCD** — Liquid crystal display. Used on some Muratec units for status displays.

**Leased line** — See *Private line*.

**Load number** — A number assigned to telecommunications equipment used in Canada; designed to help prevent overloading on a telephone circuit. See also *Ringer equivalence number*.

**Location ID** — See *Station ID*.

**lpi** — Lines per inch. The way fax image resolution is measured. (For example, see *Normal resolution*.)

**Memory** — Internal document storage. In Muratec fax machines, random access memory in the form of computer chips is used to store and hold documents for transmission and to hold some documents that have been received.

**Memory overflow** — A message that appears on the machine's LCD when the current operation requires more of the machine's electronic memory than what is available.

**MH** — Modified Huffman, the standard ITU-T Group 3 data compression method. A one-dimensional coding scheme that compresses data in a horizontal direction only. A feature of all Muratec fax machines, MH assures transmissions faster than one page per minute when communicating with other Group 3 units, regardless of manufacturer. See also *MR, MMR, MSE, SMSE*.

**Military format** — See *24-hour format*.

**Modem** — Modulator-demodulator. A device that converts digital data, like information from a fax machine, into an analog signal for transmission over ordinary telephone lines. A modem is included in a fax machine and allows it to be connected directly to a PSTN telephone line.

**MR** — Modified Read, an ITU-T Group 3 standard data compression method. A two-dimensional coding scheme that compresses data in both horizontal and vertical directions and allows for faster transmission when communicating with other Group 3 units, regardless of manufacturer. See also *MH, MMR, MSE, SMSE*.

**MMR** — Modified Modified Read, an ITU-T Group 3 standard data compression method. A two-dimensional coding scheme that compresses data in both horizontal and vertical directions and allows for faster transmission when communicating with other Group 3 units, regardless of manufacturer. See also *MH, MR, MSE, SMSE*.

**Monitor** — A speaker in most Muratec fax machines which allows the user to hear the dialing process. This is not a speakerphone, because it has no microphone for speaking to the person being called. For regular two-way voice communication, users must use the optional handset. See also *On-hook dialing*.

**MSE, SMSE** — Muratec's proprietary data compression methods, allowing a Muratec-manufactured fax machine to transmit more quickly when communicating with another Muratec-manufactured unit. MSE and SMSE are features on many Muratec fax machines. See also *MH, MR, MMR*.

**Normal resolution** — Shown as "norm"; 203H × 98v lpi. The default resolution mode for all Muratec fax machines.

**One-touch dialing** — Allows the fax user to store frequently used fax numbers for dialing with the touch of one key. See also *Autodialing* and *Speed-dialing*.

**On-hook dialing** — Dialing numbers by using the keypad on the fax unit without lifting a handset. On most Muratec fax models, the user can do this either silently or by using the monitor. See also *Monitor*.

**Original document size** — The largest (or smallest) document that can be fed safely through a fax machine.

**Override** — To change existing settings.

**Paper sizes** — All are width × length:

Letter-sized = 8.5" × 11.0" (216 × 279 mm)      Legal-sized = 8.5" × 14.0" (216 × 356 mm)

A5 = 5.8" × 8.3" (148 × 210 mm)

B5 = 7.2" × 10.1" (182 × 257 mm)

A4 = 8.3" × 11.7" (210 × 297 mm)

B4 = 10.1" × 14.3" (257 × 364 mm)

A3 = 11.7" × 16.5" (297 × 420 mm)

**Passcode** — A four-digit code-number. On your fax machine, the protection passcode lets the user limit access to fax operations, as well as certain settings and even documents readied for polling (in the case of polling, only calling machines whose users enter the proper passcode will be able to poll the document.)

**PBX (or PABX)** — Private branch exchange; privately-owned telephone equipment serving a particular building, business or area. Many PBX systems use digital transmission lines which, unlike more common PSTN lines, are not compatible with fax machine use. The user should not connect a fax unit to a PBX without first checking with the system manufacturer or service representative.

**PCL** — Page Control Language. An industry standard for printer control. Some Muratec fax machines include or offer PCL-compatible printing for Windows-based personal computers.

**Platen** — A traditional copier-style top to a fax machine or digital copier. Some Muratec fax machines and multifunctional products include a platen top, allowing you to fax from books and other awkward sources.

**Polling** — Automatic transmission to a calling remote fax, or reception of a document from a remote fax set for this operation. Polling is convenient whenever a central unit must receive information from one or several remote faxes. The caller bears all telephone charges and prevents several remote units from calling at the same time. See also *Secure polling*.

**Private line** — (Or *leased line*.) A service offered by many telephone systems; provides an exclusive phone circuit between two geographic points. A Muratec fax does not require a private line. See also *PSTN*.

**Proprietary** — Non-standard. In fax, refers to a fax feature which works only in communications between fax machines that are the same brand.

**PSTN** — Public switched telephone network; the most common type of telephone lines and service in use, in contrast to private or leased lines. A Muratec fax provides fast, reliable data transmission over a PSTN line, and does not need a special or dedicated telephone line. See also *Private line*.

**QuadAccess®** — Muratec's QuadAccess allows your Muratec fax machine to perform four or more tasks simultaneously without slowing.

**RCR** — Receive confirmation report. An RCR is your assurance that the document you transmitted was received. The RCR prints after your transmission, identifying the receiving unit and recording the date, time, transmission mode, number of pages sent and the result. The RCR is an exclusive feature of Muratec fax machines and is available only when transmitting to other, compatible Muratec fax machines. See also *TCR*.

**Receiver ID** — See *Station ID*.

**Redialing** — The dialing again, either manually or automatically controlled, of the most recently dialed fax or phone number. Automatic redialing follows an unsuccessful dialing attempt and can be done manually or automatically.

**Relay broadcasting** — Lets some Muratec fax machines store a document in internal memory, transmit the document to the memory of a remote “hub” fax and then instruct that unit to relay (re-transmit) the document to each fax in a call group in the “hub” unit. This feature speeds extremely high-volume fax communication and allows a single command to initiate document transmission to hundreds of preprogrammed fax locations. It also saves phone charges for the originating machine. Your machine can initiate a relay broadcast.

**Remote fax machine** — The machine on the other “end” of a fax communication.

**REN** — See *Ringer equivalence number*.

**Resolution** — The resolution of documents transmitted or copied by fax machines is measured by the number of horizontal (H) and vertical (V) lines per inch (lpi) the unit can print. A Muratec unit may offer one or more of these resolution levels:

Normal	203H × 98V lpi
Fine	203H × 196V lpi
Superfine	203H × 392V lpi

Some Muratec units also offer grayscale transmission (see also *Grayscale*) for accurate reproduction of photographs and other shaded originals.

**Ringer equivalence number** — Also called *REN*. A number assigned to telecommunications equipment used in the United States; designed to prevent overloading on a telephone circuit. See also *Load number*.

**Scanning width** — See *Effective scanning width*.

**SecureMail** — Allows a Muratec fax user to send a document to or receive one into (usually something confidential) an “electronic mail box.” The transmission is protected at the receiving Muratec fax by an access code; the receiving fax prints the document only when an authorized user enters the code.

**Secure polling** — Polling in which preset passcodes are checked between two machines before polling is allowed to take place.

**Speed-dialing** — Allows the fax user to store frequently used fax numbers for dialing with the touch of three keys — an identifier key (either \* or #) and then a three-digit code — for each number. See also *Autodialing* and *One-touch dialing*.

**Station ID** — (Also called *Location ID* or *Receiver ID*.) An autodialer feature which lets the fax user enter a descriptive name to correspond with the number in an autodialer entry. For example, rather than entering only *1-972-555-3465*, the user can enter that number and a name, such as *Dallas Branch Office*. (Many Muratec models with this feature allow entry of both upper-case and lower-case letters, for greater ease of reading.)

**Subaddressing** — An ITU-T standard allowing fax machines to specify special delivery characteristics of a transmission. For example, subaddressing allows fax machines from different manufacturers to send and receive messages into confidential memory mailboxes, or to retrieve specific files from polling memory.

**Subscriber ID** — A fax machine’s telephone number, as identified by a user setting. See *TTI*.

**Super Group 3** — An extension of Group 3 fax technology standards, allowing the use of high-speed v.34 modems for 33.6 Kbps transmission and high-speed protocols for rapid handshaking.

**Superfine resolution** — 203H × 392V lpi. Your Muratec fax machine’s superfine transmission mode is Group-3-compatible, not the more limited proprietary version.

**TAD** — Telephone answering device, or answering machine. Records incoming voice messages for playback. You can connect a TAD to a Muratec fax machine and use the two on one phone line.

**TCR** — Transmit confirmation report; this provides proof that your Muratec fax did send the document you set for transmission. Printed after transmission, the TCR also identifies the telephone number to which the fax sent the document, plus the actual time of transmission and how many pages the unit transmitted. See also *RCR*.

**Thermal (paper) printing** — A thermal head heats chemically treated, thermally sensitive paper in patterns conforming to the image the machine has scanned, creating a printed image. Thermal paper’s tendency to discolor and fade, in addition to its curliness and the usual difficulty in writing on it, have made this method considerably less popular than plain-paper fax printing — particularly as plain-paper fax machines have dropped sharply in price.

**TriAccess** — Muratec’s TriAccess allows a Muratec fax machine to perform three or more tasks simultaneously without slowing.

**TTI** — Transmit terminal identifier. A user-programmable line of information sent automatically with every page a fax machine sends; it appears at the top of each page printed by the receiving unit.

**Transmission speed** — How fast a fax machine is sending a fax document. This speed depends upon the modem speed of each unit, the resolution setting, the content of the document, the encoding technique and the condition of the phone line (clean, noisy, etc.) Any change in any one of these five conditions will affect the speed, sometimes significantly.

**v.29 and v.27 ter** — A standard set of communication procedures allowing fax machines to talk to other units using those standards. Specifically, these standards cover fax transmission at 9600 bps or slower.

**v.34** — An international standard for fax modems — and other modems — with transmission speeds of up to 36.6 Kbps. It represents the current maximum standard transmission speed possible under ITU-T Group 3.

**White-line skip** — A technique used to speed up fax transmission by bypassing redundant areas, such as white space.

# Appendix and index

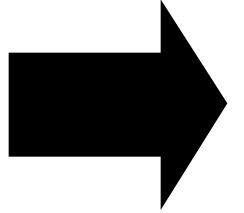

# Specifications

## General

Type:	Desktop plain paper facsimile
Compatibility:	ITU-T Group 3 and Super Group 3
Phone system:	Public Switched Telephone Network (PSTN) or equivalent
Dual access:	Multitasking QuadAccess
Memory capacity:	Standard: 8MB (650 pages* approx.) Upgrade Option: plus 8MB (additional 680 pages* approx.) = total 1330 pages*. plus 24MB (additional 2,040 pages* approx.) = total 2,690 pages*.
Memory backup time:	(Total memory capacity: Backup time) 8MB : 72 hours 16MB: 36 hours 32MB: 18 hours (Must be charged for at least 24 hours to reach full charge)
LCD (Liquid Crystal Display):	30 characters × 4 lines

## Communication

Coding method:	ITU-T-standard MMR, MR, MH and JBIG.
Modem speed:	33,600, 31,200, 28,800, 26,400, 24,000, 21,600, 19,200, 16,800, 14,400, 12,000, 9,600, 7,200, 4,800, 2,400 bps
Error correction mode:	Yes
Polling/Broadcasting:	330 locations / 330 locations
Transmission speed:	Approx. 3 seconds per page.**
One-touch dial:	56 locations
Speed dial:	244 locations

## Document input

Document set:	Face Up
Original reference position:	Center
Scanning resolution:	(horizontal × vertical): Transmission: Normal: 203 dots/inch × 98 lines/inch Fine: 203 dots/inch × 196 lines/inch Superfine: 406 dots/inch × 392 lines/inch*** Grayscale (Memory Tx): 203 dots/inch × 196 lines/inch (Real time Tx): 406 dots/inch × 392 lines/inch***
Scanning method:	Flatbed CCD
Scanning speed:	(horizontal × vertical): Transmission: Normal: 1.86 sec/page Fine: 1.86 sec/page Superfine: 3.71 sec/page Grayscale: 1.86 sec/page Copy: Normal: 1.90 sec/page Fine: 2.84 sec/page Superfine: 3.79 sec/page Grayscale: 2.84 sec/page
Scanning width:	8.2 inch (Fax), 8.5 inch (Copy)
Acceptable document size :	(width × height) Single sheet: Maximum 11 inches × 35.4 inches, Minimum 4.7 inches × 3.9 inches Two or more sheets : Maximum 10.1 inches × 14.3 inches, Minimum 8.5 inches × 5.5 inches
ADF capacity:	80 sheets of letter or A4 sized-paper 50 sheets of legal or B4 sized-paper

## Appendix and index

Document thickness: 30.2–104.7 g/m<sup>2</sup>, 13-24 lb (Single sheet)  
52.3–80 g/m<sup>2</sup>, 13-20 lb (Two or more sheets)

Grayscale: 256-level

### Printout

Printer resolution: 600 dpi × 600 dpi  
Paper exit system: Face up exit system  
Printing method: LED scanning, Electrophotographic dry powered image transfer to plain paper  
Print speed: 17 ppm, letter size, from 1st paper cassette  
Printing margin: 0.12 inch (3 mm) on each side of the paper.  
Smoothing print: Yes  
Printing paper size: Paper cassette;  
Letter, Legal, Half-letter  
Bypass tray; \*\*\*\*  
Letter, Legal, Half-letter, A4, A5, A6, F4, Executive,  
DL, CM10, Monarch, Postcard (3.9 × 5.8 inches)  
Paper capacity: Paper cassette; 500 sheets (60–90 g/m<sup>2</sup>, 20–24 lb)  
Bypass tray; 50 sheets (60–90 g/m<sup>2</sup>, 20–24 lb)  
Receiving paper tray capacity: 300 sheets (60–90 g/m<sup>2</sup>, 20–24 lb)

### Power

Power source: 120V AC 50/60 Hz.  
Power consumption: Sleep mode : Approx. 8.7 W  
Standby : Approx. 110 Wh  
Transmission : Approx. 31 W  
Reception : Approx. 960 W  
Copying : Approx. 920 W  
Maximum : Approx. 1030 W

### Operating Environment

Environmental temperature: 10° C to 32° C (50° F to 89.6° F)  
Relative humidity: 20 to 80% RH

### Miscellaneous

Weight: Approx. 43.7 lb (19.8 Kg)  
Dimensions : Width 18.3 × Depth 20.8 × Height 14.2 (inches)  
Drum cartridge life: Approx. 16,000 pages\*\*\*\*\*  
Toner cartridge life: Approx. 11,000 pages\*\*\*\*\*

\* Using the ITU-T Test Document 1 to a Muratec fax machine with normal resolution.

\*\* Based on transmission of ITU-T Test Document 1 to a Muratec fax machine. Your transmission times will vary, but your fax machine always will provide the fastest transmission speeds possible under ITU-T guidelines and phone-line conditions.

\*\*\* In the case that the remote fax has the ability of “406 dpi × 392 lpi”.

If not, the superfine resolution is “203 dpi × 392 lpi”, and the grayscale resolution in real time transmission is “203 dpi × 196 lpi”.

\*\*\*\* The A4, A5, A6, F4, Executive, DL, CM10, Monarch and Postcard (3.9 × 5.8 inches) can be used only if the optional printer controller has been installed.

\*\*\*\*\* Based on 4% document coverage and letter-sized two-page interval printing.

**Note:** Specifications are subject to change without notice.

# Regulatory information

## United States of America

### *Federal Communications Commission (FCC) information*

*Ringer Equivalence Number (RENS): F-360: AC REN, 2.2B; DC REN, 0.3.*

This facsimile machine has been tested and found to comply with the limits for a Class A digital device, pursuant to Part 15 of the FCC rules. These limits are designed to provide reasonable protection against such interference in a residential installation.

This equipment generates, uses and can radiate radio frequency energy and, if not installed and used in accordance with the instructions, may cause harmful interference to radio communications. However, there is no guarantee that interference will not occur in a particular installation.

If this equipment causes interference in radio or television reception (which can be determined by turning the equipment off and on), the user is encouraged to try to correct the interference by one or more of the following measures:

- Reorient or relocate the receiving antenna.
- Increase the separation between the equipment and receiver.
- Connect the equipment into an outlet on a circuit different from that to which the receiver is connected.
- Consult the dealer or an experienced radio/TV technician for help.

This equipment complies with Part 68 of the FCC rules. On the bottom of this equipment is a label that contains, among other information, the FCC registration number and REN for this equipment. If so requested, you must provide this information to the telephone company.

An FCC-compliant telephone cord and modular plug are provided with this equipment. This equipment is designed to be connected to the telephone network or premises wiring using a compatible modular jack which is Part-68-compliant.

### *Telephone company procedures*

The goal of the telephone company is to provide you with the best service it can. In order to do this, it may occasionally have to make changes in its equipment, operations or procedures. If these changes might affect your service or the operation of your equipment, the telephone company will give you notice, in writing, to allow you to make any changes necessary to maintain uninterrupted service.

If you have any questions about your telephone line, such as how many pieces of equipment you can connect to it, the telephone company will provide this information upon request.

In certain circumstances, it may be necessary for the telephone company to request information from you about the equipment which you have connected to your telephone line. Upon request of the telephone company, provide the FCC registration number and the Ringer Equivalence Number (REN) of the equipment which is connected to your line. Both of these numbers are listed on the equipment label attached to your fax machine.

The sum of all RENS on your telephone line should be fewer than five (5) in order to assure proper service from the telephone company. Sometimes, a sum of five (5) may not be usable on a given telephone line.

**Note:** This equipment is hearing-aid-compatible (HAC).

**Notice:** The Telephone Consumer Protection Act of 1991 makes it unlawful for any person to use a computer or other electronic device to send any message via a telephone fax machine unless such message clearly contains, either in a margin at the top or bottom of each transmitted page or on the first page of the transmission, the date and time it was sent and an identification of the business or other identity, or other individual sending the message and the telephone number of the sending machine or such business, entity or individual. For instructions on programming this information (the "TTI") into your fax machine, see pages 1.18–1.20.

### *Type of service*

Your fax is designed for use on standard-device telephone lines. The fax connects to the telephone line with a standard line called the USOC RJ-11. Connection to telephone-company-provided coin service (central-office-implemented systems). Connection to party line service is subject to State tariffs.

### *If problems arise*

If any of your telephone equipment is not operating properly, you should immediately remove it from your telephone line, as it may cause harm to the telephone network. If the telephone company notes a problem, they may temporarily stop service. When practical, they will notify you before this disconnection. If advance notice is not feasible, you will be notified as soon as possible. When you are notified, you will be given the opportunity to correct the problem and will be informed of your right to file a complaint with the FCC.

In the event repairs are ever needed on your fax machine, they should be done by Muratec America, Inc., or an authorized representative of Muratec America, Inc. For information, contact the Muratec Customer Support Center at 800-347-3296 (from the U. S. only).

## Canada

### *Industry Canada (IC) regulations*

*IC RINGER EQUIVALENCE NUMBER (REN): F-360: 0.8.*

This digital apparatus does not exceed the Class A limits for radio noise emissions from digital apparatus as set out in the interference-causing equipment standard entitled "Digital Apparatus," ICES-003 of the Department of Communications.

*Cet appareil numérique respecte les limites de bruits radioélectriques applicables aux appareils numériques de Classe A prescrites dans la norme sur le matériel brouilleur: "Appareils Numériques," NMB-003 édictée par le Ministre des Communications.*

**Notice:** The Canadian Department of Communications label identifies certified equipment. This certification means the equipment meets certain telecommunications network protective, operational and safety requirements. The Department does not guarantee the equipment will operate to the user's satisfaction.

Before installing this equipment, users should ensure that it is permissible to be connected to the facilities of the local telecommunications company. The equipment must also be installed using an acceptable method of connection. Sometimes, the company's inside wiring associated with a single-line individual service may be extended with a certified connector assembly (telephone extension cord). The customer should be aware that compliance with these conditions may not prevent degradation of service in some situations.

Repairs to certified equipment should be made by an authorized Canadian maintenance facility designated by the supplier. Any equipment malfunction, or repairs or alterations made by the user to this equipment, may give the telecommunications company cause to request the user to disconnect the equipment.

Users should ensure for their own protection that the electrical ground connections of the power utility, telephone lines and internal metallic water pipe system, if present, are connected. This precaution may be particularly important in rural areas.

**Caution:** Users should not attempt to make such connections themselves, but should contact the appropriate electric inspection authority or electrician.

The Ringer Equivalence Number (REN) assigned to each terminal device provides an indication of the maximum number of terminals allowed to be connected to a telephone interface. The termination on an interface may consist of any combination of devices subject only to the requirement that the sum of the RENS of all the devices does not exceed 5. The IC REN for your equipment is 0.8.



# Limited warranty

This warranty is made by Muratec America, Inc. (hereafter referred to as "Muratec"). This warranty is valid only on Muratec products purchased and used in the United States of America. This warranty applies to the product only while owned and used by the original purchaser ("Customer"). If ownership of the product is transferred, this warranty terminates. This warranty does not apply to any product in use for rental purposes.

This Muratec product is warranted against defects in material and workmanship for ninety (90) days commencing the date of original Customer purchase. If the product is defective in material and/or workmanship (normal wear and tear excepted) during the warranty period, Muratec or its authorized representative will, during Muratec's established service availability hours, make necessary adjustments and repairs, including, at Muratec's option, installation of replacement parts. Muratec's service availability hours are 8:30 AM to 5:00 PM (Central time) Monday through Friday, excluding Muratec-recognized holidays. Muratec will complete the necessary adjustments and repairs within a reasonable time period, as dictated by the nature of the problem and by Muratec's service schedule. Replacement parts may have been used and/or reconditioned. Parts that have been replaced will remain the property of Muratec. This warranty is subject to the OBLIGATIONS and EXCLUSIONS set forth.

## Obligations

1. This warranty will be honored only on presentation of the original dated authorized Muratec bill of sale or Muratec dealer bill of sale or sales slip to an authorized Muratec service representative or service center. For the name of your authorized service center, contact Muratec (from the United States, call 1-972-364-3350; from Canada, check your in-box materials for the number to call).
2. During the warranty period, the Customer must notify Muratec by telephone of any defective product material and/or workmanship.
3. Transportation (including prepayment of freight and insurance charges) of the product to and from an authorized service center, designated by Muratec, is the responsibility of the Customer.
4. If Muratec provides maintenance or responds to a call which is outside the scope of this warranty, such maintenance shall be billed to the Customer at Muratec's then-current rates for maintenance and parts and shall be due and payable in full upon receipt of invoice.

## Exclusions

1. This warranty shall not cover a product with missing or altered original identification marks.
2. This warranty applies only to products that the purchaser has properly installed, adjusted and operated in accordance with the instructions set forth in or provided with product literature. This warranty does not apply to any product which has been subjected to tampering, alteration, misuse, abuse, neglect, improper installation or transportation damage. Nor does it apply to costs for any service requested for demonstration or to confirm proper operation of this product.
3. The warranty shall not apply to adjustments, repairs or replacements necessitated by any cause beyond the control of Muratec (whether foreseeable or not) including, but not limited to, any malfunction, defects or failure caused by or resulting from any of the following: improper unpacking or installation, unauthorized service or parts, or improper maintenance or cleaning, modification or repair by the Customer, accident (including, without limitation, unavoidable accidents), fire, flood or other Acts of God, improper telephone or electrical power or surges thereof, interconnection with or use of non-compatible equipment or supplies (including paper), or placement of the product in an area which does not conform to Muratec space, electrical and/or environmental requirements.
4. Muratec will not be required to make adjustments, repairs or replacements if the product is installed or used at a location deemed by Muratec to be hazardous to health or safety, or if Muratec is not provided with free and reasonable access to the product and a telephone during service availability hours, or if the product location is not accessible by an authorized Muratec service vehicle.

EXCEPT AS EXPRESSLY SET FORTH ABOVE, AND EXCEPT TO THE EXTENT PROHIBITED BY APPLICABLE LAW, MURATEC MAKES NO OTHER WARRANTIES, EXPRESS OR IMPLIED (INCLUDING, BUT NOT LIMITED TO, ANY IMPLIED WARRANTIES OF MERCHANTABILITY OR FITNESS FOR A PARTICULAR PURPOSE, AND ANY WARRANTY ARISING FROM COURSE OF DEALING OR USAGE OF TRADE), AND MURATEC EXPRESSLY DISCLAIMS ALL WARRANTIES NOT STATED HEREIN. IN THE EVENT THE PRODUCT IS NOT FREE FROM DEFECTS AS WARRANTED ABOVE, THE CUSTOMER'S SOLE REMEDY SHALL BE REPAIR OR REPLACEMENT AS PROVIDED ABOVE. UNDER NO CIRCUMSTANCES SHALL MURATEC BE LIABLE TO THE CUSTOMER, OR TO ANY USER, FOR ANY DAMAGES, INCLUDING ANY INCIDENTAL OR CONSEQUENTIAL DAMAGES, EXPENSES, LOST PROFITS, LOST SAVINGS OR ANY OTHER DAMAGES ARISING OUT OF THE USE OR INABILITY TO USE THE MURATEC PRODUCT, EVEN IF MURATEC OR ITS REPRESENTATIVES HAVE BEEN ADVISED OF THE POSSIBILITY OF SUCH DAMAGES.

Some States do not allow the exclusion or limitation of incidental or consequential damages, and some States do not allow limitations on how long an implied warranty lasts, so the above limitations or exclusions may not apply to you. This warranty gives you specific legal rights, and you may also have other rights which vary from State to State.

# Index

- A**
- AC power cord . . . . . 1.1
  - AC power switch . . . . . 1.7
  - Activity journal . . . . . 3.22
  - Autodialer . . . . . 3.1
    - call group . . . . . 3.7
    - dialing characters . . . . . 3.1
    - one-touch dialing . . . . . 3.2
    - speed-dial . . . . . 3.4
- B**
- Batch transmission . . . . . 3.12
    - Creating or modifying . . . . . 3.12
    - Erasing a document . . . . . 3.14
    - Erasing an empty batch box . . . . . 3.14
    - Printing a document stored in a batch box . . . . . 3.13
    - Printing a list of batch boxes . . . . . 3.13
    - Printing a list of stored batch documents . . . . . 3.13
    - Storing a document . . . . . 3.13
  - Block JunkFax . . . . . 3.50
  - Broadcasting . . . . . 3.9
- C**
- Call group dialing . . . . . 3.6
  - Call request . . . . . 3.26
  - Canceling commands . . . . . 2.6
  - Caring for your fax machine . . . . . 5.11
    - Corrective cleaning . . . . . 5.11
  - Changing the default settings
    - for copying
      - print margin . . . . . 4.7
    - for dialing
      - pause length . . . . . 4.5
      - redial settings . . . . . 4.5
    - for operation
      - 2-bin tray . . . . . 4.9
      - Setting the silent mode . . . . . 4.8
    - for reception
      - Half-page reception . . . . . 4.3
      - Print reduction rate . . . . . 4.3
      - reduction margin . . . . . 4.3
      - the number of rings . . . . . 4.4
  - for transmission
    - Primary contrast mode . . . . . 4.1
    - Primary resolution mode . . . . . 4.1
    - Quick Memory transmission . . . . . 4.2
    - Print your settings . . . . . 4.10
  - Control Panel . . . . . 1.3
  - Copies . . . . . 2.10
    - Using the bypass tray . . . . . 2.10
  - copy light . . . . . 1.3
  - Cover page . . . . . 3.24
- D**
- Delayed transmission . . . . . 3.11
  - Department code . . . . . 3.52
  - Dialing Characters . . . . . 3.1
  - Document tray . . . . . 1.1
  - DRD (distinctive ring detection) . . . . . 3.25
  - Drum cartridge . . . . . 1.1, 1.5
- E**
- EasyDial directory dialing . . . . . 3.8
  - Error messages . . . . . 5.5
  - Extension paper tray . . . . . 1.1
- F**
- Fax & Copy . . . . . 3.21
  - Fax setting list . . . . . 1.20, 2.8, 3.50
    - Block Junk Fax . . . . . 3.50
    - contrast . . . . . 4.1
    - department code . . . . . 3.52
    - department code protection . . . . . 3.53
    - DRD . . . . . 3.25
    - ECM . . . . . 4.2
    - Half-page reception . . . . . 4.3
    - Memory transmission . . . . . 4.2
    - number of rings . . . . . 4.4
    - pin mask feature . . . . . 3.48
    - Quick Memory transmission . . . . . 4.2
    - reception modes . . . . . 2.8
    - redial . . . . . 4.5
    - Reduction margin . . . . . 4.3
    - resolution . . . . . 4.1

## Appendix and index

Rx reduction rate	4.3
Security reception	3.46
TTI transmission	4.2
Faxes	2.1
Receiving	2.8
Answering calls manually	2.8
Reception modes	2.8
Sending	2.1
canceling commands	2.6
Contrast	2.1
Dialing pause	2.2
from Memory	2.2
How to set the document	2.1
In real time	2.3
Resolution, grayscale	2.1
using monitor/call key or a handset	2.4
F-Code boxes	3.27
Bulletin box	3.27, 3.32
Creating or modifying	3.27
Erasing an empty F-Code box	3.35
F-Code polling	3.37
F-Code transmission	3.36
Printing a list of documents stored in your F-Code boxes	3.32
Printing a list of F-Code boxes	3.32
Relay box	3.28, 3.35
Security box	3.27, 3.34
Function table	1.13
<b>I</b>	
Initial settings	1.18
<b>J</b>	
Jammed paper, removing	5.1
<b>L</b>	
Location ID	3.1
<b>M</b>	
Machine setting list	1.18, 4.10
2-bin	4.9
Service Mode	1.13
Silent mode	4.8
Soft Keys	3.17
Macros	3.18
Erasing	3.20
Printing a list of your Macro keys	3.21
Programming	3.18
Memory transmission	2.2

<b>O</b>	
One-touch keys	3.2
Entering or changing	3.2
Erasing	3.2
One-touch fax dialing	3.3
One-touch phone dialing	3.3
Printing a list of one-touch numbers	3.3
One-touch labels	1.1
Operating tips	1.10
Out-of-paper reception	2.9

<b>P</b>	
paper	1.7
Acceptable paper size	1.7
Paper size setting	1.9
Pause character, entering	2.2
PIN masking	3.48
Passcode	3.46
Polling	3.15
Being polled	3.15
Regular polling	3.15
Print quality problems	5.3
Printing your settings	4.10
Machine settings list	4.10
Programmable one-touch keys	3.38

<b>Q</b>	
QuadAccess	3.27
Quick memory transmission	2.2

<b>R</b>	
Real time transmission	2.3
Receiving faxes	2.8
Redialing	2.5
Regulatory information	ai.3
Reports, confirmation	3.23

<b>S</b>	
Security features	3.46
Block Junk Fax	3.50
Department codes	3.52
Masking the pin	3.48
Passcode	3.46
Security reception	3.46
Security reception	3.46
Passcode	3.46
Sending faxes	2.1
Separator page	3.24

Setting up	1.5
Adjust the monitor speaker's volume	1.7
Attach the paper-handling parts	1.6
Initial settings	1.18
Installing the printing supplies	1.5
Pick an installation spot	1.5
Soft keys	
Setting	3.17
Special features	
Activity journal	3.22
Call request	3.26
Cover page	3.24
Distinctive ring detection (DRD)	3.25
Fax & Copy	3.21
F-Code Boxes	3.27
Macro keys	3.18
Programmable one-touch keys	3.38
Reports	3.23
Specifications	AI.1-AI.2
Speed-dial numbers	3.4
Entering or changing	3.4
Erasing	3.4
Fax dialing via speed-dial	3.5
Phoning via speed-dial	3.5
Printing a list of speed-dial numbers	3.5
Subscriber ID (your fax's phone number)	1.19
<b>T</b>	
Telephone line cord	1.1
Toner cartridge	1.1, 1.5
Troubleshooting	5.5
TTI (Transmit Terminal Identifier)	1.18
<b>U</b>	
Using the optional handset	2.12
<b>W</b>	
Warranty, limited	AI.4

*This page intentionally blank.*

# **Muratec**<sup>TM</sup>

**The Fax Specialists.**

**Muratec America, Inc.**  
6400 International Parkway  
Suite 1500  
Plano, Texas 75093  
*<http://www.muratec.com>*

